

FIELD TESTING AND NUMERICAL SIMULATION APPLIED TO DYNAMIC PROBLEMS*

Marcelo G. Pereira¹
Edmilson R. O. Santos²
Danilo A. Silva³
Renato Castro⁴
Henrique R. Severino⁵
Fernando C. Sousa⁶

Abstract

Rolling mill should have high operational reliability to avoid unscheduled shutdowns, since it significantly affect production. During the operational process high levels of vibration in certain production velocities were observed, causing Chatter Marks. In order to understand the dynamic behavior of these equipment in different conditions, and consequently to propose actions avoiding such events, field testing and numerical simulation were performed. Field testing highlighted vibrational problems caused by failures in internal components, as well as operational deflection forms related to each excitation source due to these events. Correlation of–results with those obtained numerically showed their impact on the quality of the material produced. Vibrational levels and resulting problems were attenuated after–application of suggested recommendations.

Keywords: Rolling Mill; Vibration, Chatter Marks; Operational Mode; Mode Shape.

- ¹ Engenheiro Industrial Mecânico, Engenheiro de Aplicação, SKF do Brasil LTDA, SP, Brasil.
- ² Eng./UNICAMP, Dr. em Eng. Mecânica, Eng. de Simulação Numérica, Análise Dinâmica, SKF do Brasil, Cajamar, SP, Brasil.
- ³ Engenheiro Industrial Mecânico, Engenheiro de Aplicação, SKF do Brasil LTDA, SP, Brasil.
- ⁴ Engenheiro Mecânico, Engenheiro de Simulação Numérica, SKF do Brasil LTDA, SP, Brasil.
- ⁵ Engenheiro Mecânico, Engenheiro de Simulação Numérica, SKF do Brasil LTDA, SP, Brasil.
- ⁶ Engenheiro Mecânico, Engenheiro de Simulação Numérica, SKF do Brasil LTDA, SP, Brasil.

1 INTRODUCTION

Equipment that compose the drive system of a rolling mill, should have high operational reliability. Failures can generate high financial and productive impact on companies. After around 4 years operation, marks were observed in the laminated material. All process parameters and machine setup were verified, no deviations were observed. Thus, a study was proposed to evaluate structure/equipment.

According to [1] the lamination process involves dynamic phenomena that make it self-excitable and promote mechanical vibration. The Chatter Mark is a phenomenon known in cold rolling processes of steel, aluminum and even in papermaking. In cold rolling the Chatter marks are characterized by alternating bands, clear and dark, parallel to each other and in the transverse direction of the lamination. [2] and [3] have been used in this paper to investigate the relationship between the vibration behavior and the vibration behavior. Chatter is an undesirable vibrational condition during the lamination process, which degrades the surface quality of the strip. There are cases of Chatter where the severity of vibration reaches levels that compromise the equipment [4].

2 CONTEXTUALIZATION

During the operational process high levels of vibration in certain production velocities were observed, causing Chatter Marks and generating quality problem and product waste. There are cases of Chatter in which the severity of vibrations can compromise the equipment itself. [5] classified Chatter modes in three and Meehan [6] separated them by frequency mode, as showed in Figure 1:

- 5 – 20 Hz (torsion Chatter);
- 128 – 256 Hz (third octave);
- 500 – 700 Hz (fifth octave).

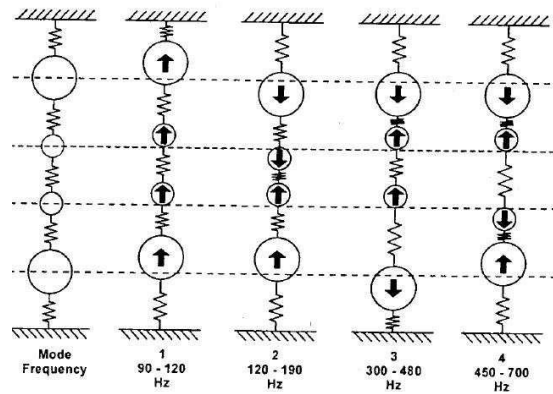
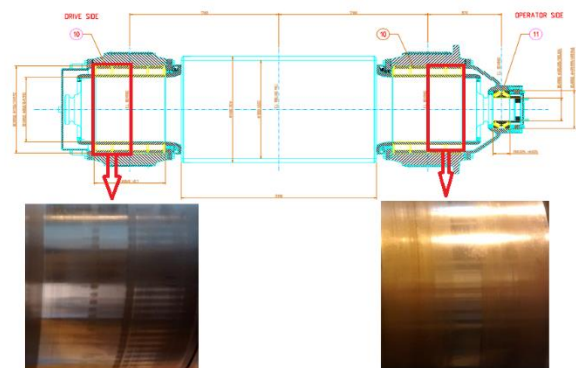


Figure 1. Vibration mode of the rolling mill

On upper Backup Roll bearings were identified indentation marks, which are highlighted on Non Operator Side (NOS) than OS (Figure 2a), and marks on plate (Figure 2b). Also, it was verified by acceleration enveloping spectrum, bearing failures indicating wear of internal components (Figure 3).



(a)



(b)

Figure 2. (a): Indentations marks identified on upper Backup Roll bearing – NOS. (b): marks on plate

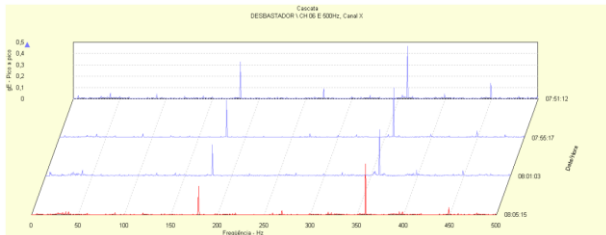


Figure 3. Acceleration enveloping spectrum, bearing failures indicating wear of internal components

Therefore, that condition can increase vibrational levels and excite Chatter modes.

3 RESULTS AND DISCUSSION

3.1. Field Testing

Instrumentation and software used in the field measurements, as well as in the numerical simulation are described in the Table 1.

Table 1. Instrumentation and software used in the field measurement, as well as, in the Numerical Simulation

Collector/Analyzer (SKF):	SKF IMX-P;
Sensors (SKF):	Accelerometers CMSS2200
Management/analysis of measurement data	@ptitude Observer 8.0.168.0;
3D CAD Software:	Creo Parametric 2.0;
Dynamic Testing and Numerical Simulation Software	ME'scopeVES 5, ANSYS® R1 2019

In Tables 2 to 5 technical data of motor and gearbox is described. Such information is relative to operation conditions used during field measurement.

Table 2. Motor data

Equipment:	Motor ABB AMZ 0900XW06 LSB
Power:	5,000 kW (6798,11 hp)
Rotation:	433/1,300 RPM

Table 3. Gearbox data

Equipment:	Gearbox Echesa T1 - 800E
Gears - idling speed:	
Number of teeth - Z1:	34
Number of teeth - Z2:	79
Gears – fast speed:	
Number of teeth - Z3:	74
Number of teeth - Z4:	70
Input shaft – Bearings:	SKF - 22252 C3 (LA)/22348 C3
Output shaft – Bearings:	SKF - 23972 C3 23068C3
Output shaft – Bearings of Gears:	TIMKEN - LM 961548/LM 961510

Table 3. Multiplier data

Number of teeth - Z1 and Z2:	34
Input shaft – Bearings:	23972 C3/23068
Output shaft – Bearings:	22348 C3/22252 C3

Table 4. Work roll data

Bearing:	LM 451349 (OS)
Bearing:	LM 451310 (NOS)

Table 5. Backup roll data

Bearing:	850RX3304AC6 (OS)
Bearing:	850RX3304AC6 (NOS)

Field measurements were performed using the following set up: 100 mV/EU; 1600 lines, end frequency 1,000 Hz, Hanning window and operational condition was high load. Figure 4 present all points where field measurements were performed on rolling mill system.

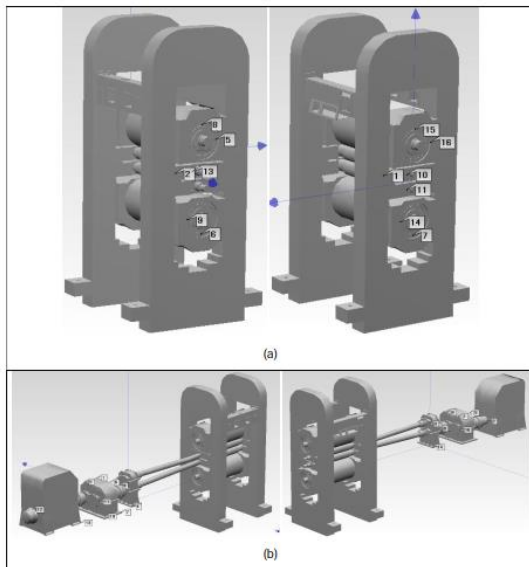


Figure 4. (a) and (b): measurement points used in the field testing.

3.1.1 Vibration Testing

Figure 1 shows points where FFT and Transmissibility measurements were taken. Table 1 shows the highest vibration levels measured in the rolling mill system.

Table 1. Highest values measured in the rolling mill system

Point	Value [mm/s]	Output speed - Workroll [Hz]
1X	15.44	4.3
-5X	16.72	4.49
6X	14.45	4.37
7Z	9.97	3.45
9Y	9.51	3.45
10Z	10.05	3.45
-11Y	9.57	3.45
-15Y	18.03	4.45
16Y	8.82	4.2

In the point 1X, located in gearbox on the input shaft, the vibration spectrum highlight the frequency of 316 Hz (GMF – Gear Mesh Frequency) with side bands of 4 Hz (output shaft speed), as shown in Figure 5. In the point 6X, located in gearbox on the output shaft, the vibration spectrum highlight the frequency of 351 Hz (GMF) with side bands of 4.49 Hz (output shaft speed), as shown in Figure 6.

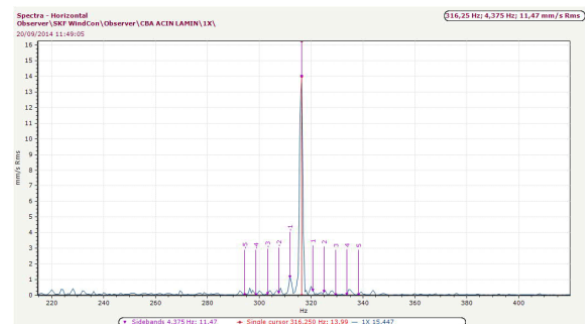


Figure 5. Vibration spectrum measured in the 1X point, it highlight 316 Hz (GMF) with side bands of 4 Hz (output shaft speed).

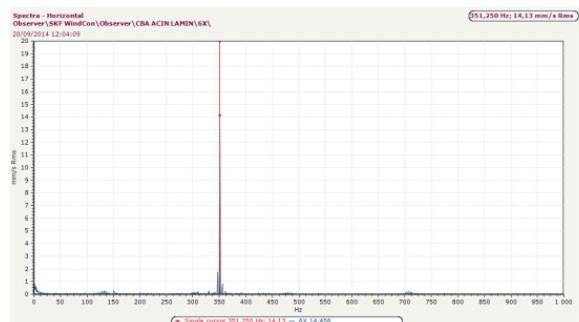


Figure 6. Vibration spectrum measured in the 6X point, it highlight 351 Hz (GMF) with side bands of 4.49 Hz (output shaft speed).

In the point -15Y, located in gearbox on the output shaft, the vibration spectrum highlight the frequency of 351 Hz (GMF) with side bands of 4.49 Hz (output shaft speed), and also it was observed the 2nd harmonic of the GMF, which represents misalignment event, according to [7] (Figure 7).

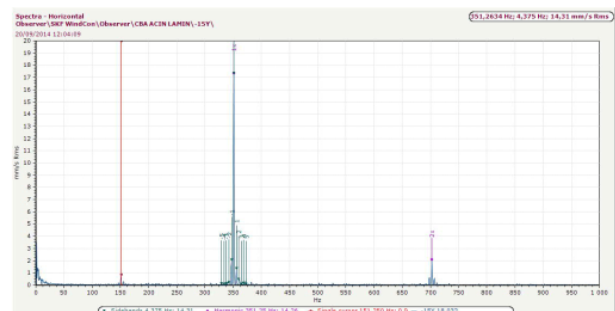
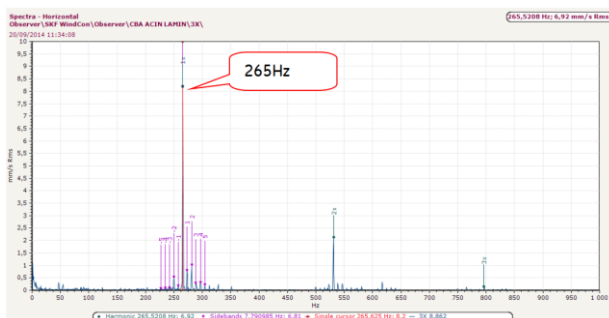
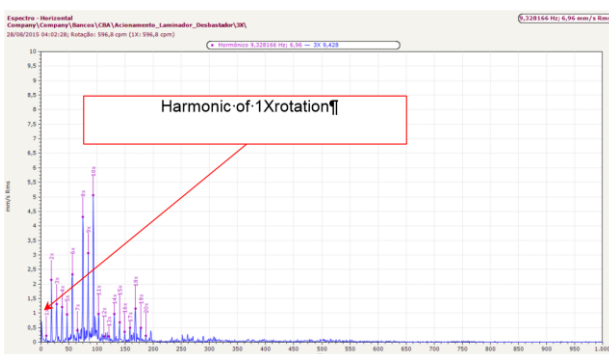


Figure 7. Vibration spectrum measured in the -15Y point highlight 351 Hz (GMF) with side bands of 4.49 Hz (output shaft speed). Also, it was observed the 2nd harmonic of the GMF, which represents misalignment event

In the point 3X, located in multiplier on the output shaft, the vibration spectrum highlight the frequency of 265 Hz (GMF - multiplier) with sidebands of 7.89 Hz (output shaft speed of gearbox), and also it was observed the 2nd harmonic of the GMF (530 Hz), which represents misalignment event, according to [7] (Figure 8a). Also, it was observed mechanical looseness due to harmonics of multiplier output shaft speed, according to [7] (Figure 8b).



(a)



(b)

Figure 8. Spectra measured on point 3X. (a): 265 Hz (GMF) highlighted with sidebands of 7.89 Hz, and misalignment event due to 2nd harmonic of the 265 Hz. (b): mechanical looseness due to harmonic of multiplier output shaft speed.

3.1.2 Dynamic Testing

Vibration result shows 350 Hz and 266 Hz highlighted in the spectra, and such frequencies refers to gear mesh frequency of the gearbox and multiplier. Therefore, analysis performed by Dynamic Testing in the 350 Hz and 266 Hz showed relative movements of the gearbox and multiplier

frame, which generates misalignment between the gears [8], according to spectra in Figures 7 and 8a. Figures 8 and 9 show the dynamic behavior of gearbox and multiplier frame in 350 Hz and 266 Hz, respectively.

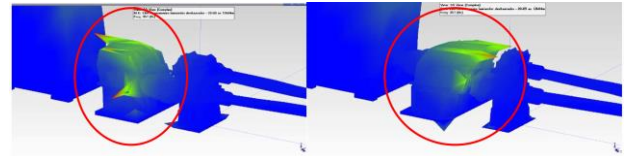


Figure 8. Operational Mode in 350 Hz generate relative movements of gearbox frame, and consequently misalignment between gears

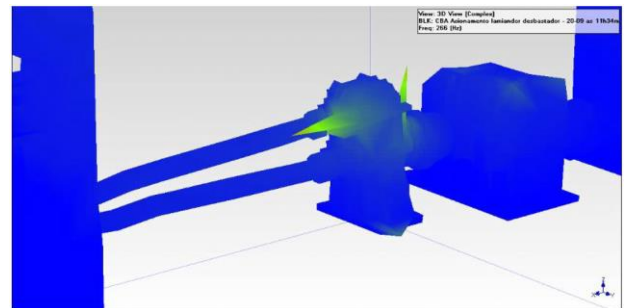


Figure 9. Operational Mode in 266 Hz generate relative movements of multiplier frame, and consequently misalignment between gears

3.1.3 Numerical Modal Analysis of Rolling mill System

In this numerical model used structural steel ASTM A-36 [9]. 3D numerical model of the gearbox was discretized with a mesh of 55135 elements (Figure 10).

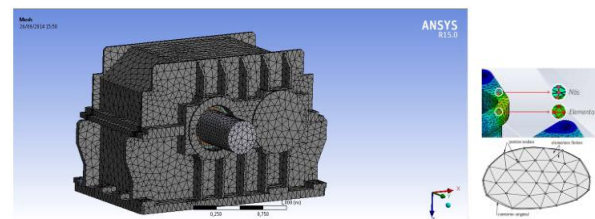


Figure 10. Mesh applied to gearbox frame discretized with a mesh of 55135 solid elements.

To perform system Numerical Modal Analysis, following boundary condition was applied:

- Metal base fixed support, Figure 11.

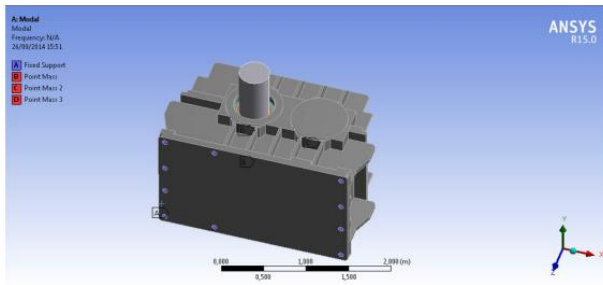


Figure 11. Boundary condition applied to frame gearbox system.

Table 4. Natural Frequencies of the first 25 and its respective mode shapes gearbox system

Mode Shapes	Natural Frequency [Hz]
1	3.3636
2	3.8466
3	71.576
4	137.48
5	149.9
6	150.73
7	179.68
8	194.12
9	200.68
10	244.99
11	249.06
12	258.26
13	265.51
14	286.32
15	306.28
16	308.95
17	314.37
18	351.16
19	370.57
20	372.95
21	393.16
22	395.96
23	407.29
24	418.95
25	438.88

Numerical results presented in Table 2 shows natural frequencies and their respective mode shapes. Natural frequencies: 351.16 Hz, 370.57 Hz and 372,95 Hz are around 351 Hz identified in Vibration Testing (Figure 4), which has vibrational energy able to excite operational modes observed in Dynamic Testing. Figure 12 highlight movements in

the output shaft, which generates misalignment between gears, according to observed in the Figure 8a. Figures 13 and 14 presented mode shapes of gearbox frame, which are local modes located on upper side of gearbox frame. Therefore, it will not cause gear problems.

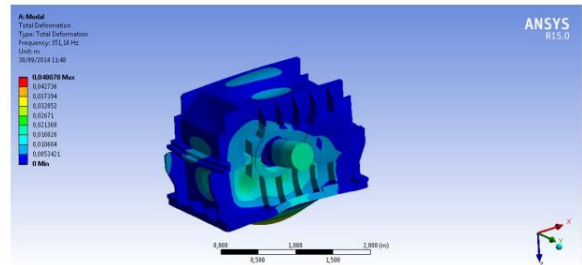


Figure 12. Mode shape in 351.16 Hz.

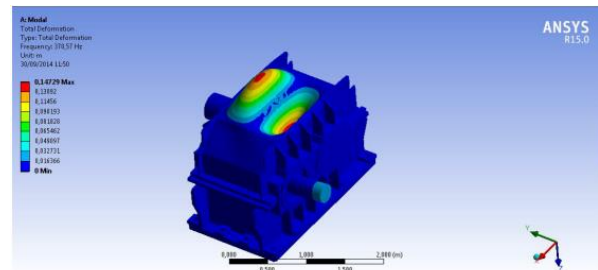


Figure 13. Mode shape in 370.57 Hz.

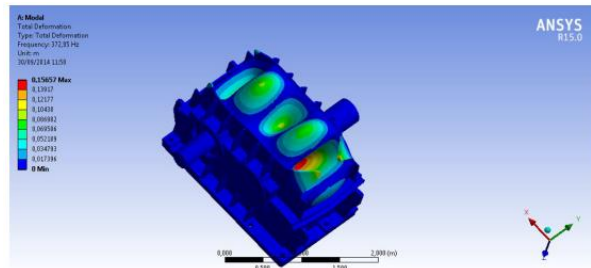


Figure 14. Mode shape in 372.95 Hz.

Operational mode in 351 Hz was correlated to mode shape obtained numerically in 351.16 Hz, and it was observed horizontal movements located on output shaft of the gearbox, as showed in Figure 15a and 15b, respectively. Therefore, it was observed that mode shape and operational mode by Dynamic Testing in each respective frequencies presented the same dynamic behavior. Then, numerical model is calibrated, and so it was presented the proposal to avoid gearbox frame resonance.

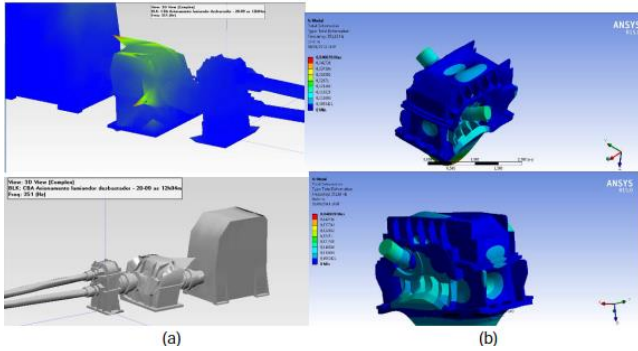


Figure 15. (a): operational mode obtained by Dynamic Testing in 351 Hz and (b): mode shape in 351.16Hz

Dynamic behavior of gearbox in 351 Hz cause misalignment, which was transferred to rolling mill, generating marks on the plates. Phenomenon of chatter was correlated with resonance frequency in 351 Hz from marks identified on the plate, which occur every 10 mm. Considering the frequency with the highest vibrational energy identified in the system was 350 Hz, and backup roll has a rotation of 1.2 Hz, so it is possible to calculate the time that the inner ring need to complete one cycle:

$$Hz=1/1.2=0.833 \text{ s (cycle/second).}$$

Then, to run the entire perimeter 2915.39 mm, the inner ring takes 0.833 s. Therefore, time between 10 mm mark is obtained by simple calculation:

$$\frac{2915.39 \text{ mm}}{10 \text{ mm}} = \frac{0.833 \text{ s}}{x}$$

Therefore, result is 0.00285 s and frequency is given by Equation 2:

$$f=1/T \tag{2},$$

result of the Equation 2:
 $f=1/0.00285 \text{ s}=349.98 \text{ Hz}$

Frequency marks of the plate will occur in 349.98 Hz, which corresponds to the frequency of higher energy found in the system, where resonances of the gearbox frame was identified. Also, it was evaluated the rolling mill, and it was verified that there are mode shape around 350 Hz, according to Figure 16. Therefore, it is confirmed that plate marks are

caused by resonant behavior of rolling mill in 350 Hz.

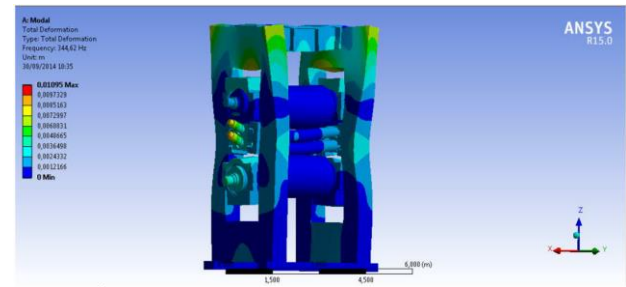


Figure 16. Mode shape in 344.62 Hz.

To minimize these resonant operating conditions rolling mill around 350 Hz some proposal were presented, such as: alignment and geometry of the entire drive system, verification of all mechanical looseness of internal components, check alignment and geometry of cardan system after intervention on the gearbox. Finally, an online monitoring system was installed to correlate process conditions with vibrational response of the system, avoiding resonant conditions.

3.1.4 Vibration and Dynamic Testing After Proposal of Application

In the point -15Y, located in gearbox on the output shaft, the vibration spectrum of the current condition (first measurement), which highlight the frequency of 351 Hz (GMF) with side bands of 4.49 Hz (output shaft speed). It was also observed the 2nd harmonic of the GMF, which represents misalignment event (Figure 17a). After proposal application (second measurement), there is only 418 Hz gear frequency is observed, without misalignment event, as shown in Figure 17b.

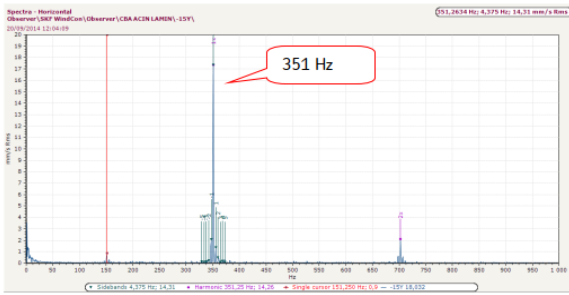
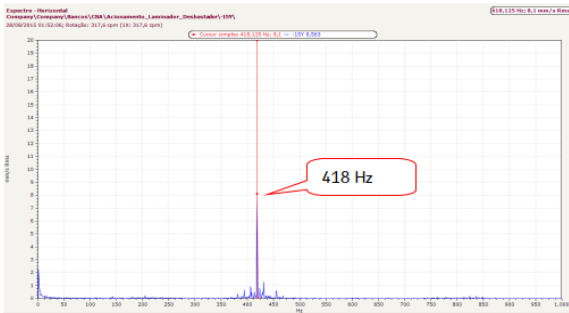
(a) 1st Measurement(b) 2nd Measurement

Figure 17. (a): Vibration spectrum of current condition measured in the -15Y point. It highlight 2nd harmonic of the GMF, which represents misalignment event (b): After proposal application (second measurement), only 418 Hz gear frequency is observed, without misalignment event

Comparing dynamic result of the current condition result with proposal application, it was observed that relative movements on output shaft region (Figure 18) are not occurring in the second condition (Figure 18). Relative movements are located on gearbox frame, which will not cause misalignment, and consequently chatter problem.

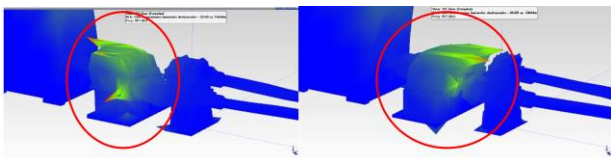


Figure 18. Operational Mode in 350 Hz generate relative movements of gearbox frame, and consequently misalignment between the gears

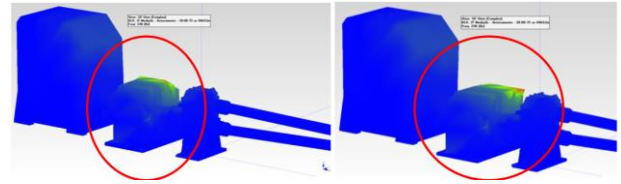


Figure 18. Operational Mode in 350 Hz generate relative movements of gearbox frame, and consequently misalignment between the gears

4 CONCLUSION

Dynamic behavior of gearbox cause relative movements, which generates misalignment, and consequently, mode shape of rolling mill are excited. The shape mode around 350 Hz causes marks on plate, confirming problems caused by resonant behavior of rolling mill. To minimize these resonant operating conditions rolling mill some proposal were applied.

REFERENCES

- 1 Roberts, WL. Four-high mill stand chatter of fifth-octave mode, AISE Year Book (1978), pp.396-402;
- 2 Y. Kimura, Y. Sodani and N. Nishiura "Analysis of Chatter in Tandem Cold Rolling" Proceedings of the 49th Japanese Joint Conference for the Technology of Plasticity, November 21 to 23, 1998, Hachioj;
- 3 Aigner, H.; Helekal G. and Hofmann W. Huge Reduction of Chatter Marks by Using Automatic Inline Control Simultaneously at the Grinding Machines, Temper and Cold Rolling Mill" 1999 Aise Annual Convention and Exposition;
- 4 Yun, IS; WRD Wilson, Ehmann KF Chatter in the Strip Rolling Process, Part I, Dynamic Model of Rolling" Journal of Manufacturing Science and Engineering, Transactions of the ASME, Vol. 120, May 1998;
- 5 Roberts, WL.: "Four-high mill stand chatter of fifth-octave mode" AISE Year Book, pp.396-402, 1978;
- 6 Meehan, P. A. W. John Edwards and Glen A. Wallace "Modelling And Simulation of Vibration Phenomena in Rolling Mills" 7th International Conference

- on Steel Rolling, Tokyo, Japan - October 1998
- 7 Technical Associates of Charlotte, Use of Vibration Signature Analysis to Diagnose Machine Problems, 1997;
 - 8 Onari, M. M., Boyadjis, P.A., Solving Structural Vibration Problems Using Operating Deflection Shape and Finite Element Analysis, Proceedings of the Twenty-Fifth International Pump Users Symposium, pages 85 to 102, 2009;
 - 9 Ansys® Workbench 2019 – R1, Database of Materials.