

NEW FINISHING ROLLING MILL FOR HIGH ALLOY STEEL- GRADES AT VILLARES METALS / BRASIL ¹

*Karl Berger²
Luigi Giacomini²
Josef Gahleitner²
Luiz Carlos Garcia³
Edmir Ranzani³
Marcos Stuart³
Wilfried Meyer³*

Abstract

The long rolling technology for specialty and high alloy steel grades has developed significantly in the last years. To achieve higher productivity, best quality and higher flexibility for small lots VILLARES METALS SA has invested in a New Finishing Rolling Mill in their plant. The mill started up in early 2007 and achieved tightest tolerances in all the three production lines for: Bars (round, squares, hexagons, octagons, small flats); Wide Flats up to 250 mm width; Wire Rod with diameter of 5.0 mm (minimum). The paper describes the installed equipment and components and their benefits as also latest developments of several equipment groups applied to this mill. Enhanced technology - such as CCR (Compact Cassette Rolling) - permits to achieve the required production parameters.

Key words: Long rolling; High alloy grades; Compact cassette rolling.

NOVO LAMINADOR – MULTILINE - PARA ALTAS LIGAS NA VILLARES METALS

Resumo

A tecnologia de laminação para aços especiais de alta liga, desenvolveu significativamente nos últimos anos. Para atingir alta produtividade, ótima qualidade e mais flexibilidade para lotes pequenos, a VILLARES METALS SA investiu em um novo laminador de acabamento – multi line – na planta de Sumaré. O laminador começou a produzir no início de 2007 e já atingiu as melhores tolerâncias nas 3 linhas (linha de barras, linha de chatos largos, linha de fio máquina). Este trabalho explica os equipamentos e componentes instalados e os benefícios dos últimos desenvolvimentos. A tecnologia avançada, como a de CCR (Compact Cassette Rolling) permite a atingir os parâmetros solicitados.

Palavras-chave: Laminação de longos; Alta liga; Laminador tipo cassete.

¹ *Technical contribution to 44th Rolling Seminar – Processes, Rolled and Coated Products, October 16 to 19, 2007, Campos do Jordão – SP, Brazil.*

² *Engineers of Siemens VAI Metals Technologies in Marnate (Milan) / Italy and Belo Horizonte, MG / Brazil*

³ *Engineers of Villares Metals SA in Sumaré, SP / Brazil.*

1 INTRODUCTION

VILLARES METALS SA (VMSA) is the Latin American leading producer of long products in high-alloy steels, and one of the top 3 world producers of valve steel products. Besides serving the domestic market and Mercosul, VMSA exports to USA, Europe and other countries. VMSA merged in 2004 in the Austrian group Böhler-Uddeholm. Its production facility is located in Sumaré, São Paulo state.

SIEMENS VAI METALS TECHNOLOGIES (SVAI) is the world leading full-line plant provider for steel and aluminum industries, with a product portfolio covering the whole spectrum of mechanical, electrical and automation technologies and services. SVAI's business unit for Long Product Rolling (former VAI POMINI) is based in Marnate near Milan, Italy.

VMSA used to have two facilities: the Sumaré plant and the Sorocaba plant, which was shared with Aços Villares S.A. Since Böhler-Uddeholm acquired VMSA, the plan to leave the Sorocaba plant became the driving force to concentrate all the rolling production in Sumaré. The concentration of the production in a single site, and the use of state-of-art equipment are both crucial factors which favor the reduction of production costs by increasing the productivity.

The new Multi-Line Finishing Mill has therefore been installed, commissioned during 2006 and started up in early 2007. The mill has been designed for highest flexibility to handle the small order lots, and incorporates a high level of automation for inline control of process parameters. The shift productivity will be increased from former 30 to future 100 tons/shift for all the wide range of special grades that VMSA is producing.

With this investment VMSA is able to offer – beside the different bar sizes - new products, as wide flat bars and bigger coil weights at smaller diameters for wire rod.

SVAI has delivered and installed the new mill on a turn-key basis, providing the mechanical equipment as well the process know-how and the electrical and automation system using SIEMENS products.

The “core” line of the mill is the bar line, where the bar transferred from the 3-Hi rougher enters through the equalizing furnace. A total of 16 CCR-type stands in 45° arrangement are divided in four groups, with crop and dividing shears located in between.

The CCR (Cassette-type Compact Rolling) technology permits to change cassettes quite quickly whenever a new family is rolled. Groove changes and gap adjustment allow to adapt to the fast changing process parameters.

A flat rolling line, able to produce wide flats, can work totally independently from the bar mill and thus reduce the set up time of the complete line.

The wire rod line is the 3rd line of the mill. A Monoblock arrangement of 2 split blocks in tandem configuration (6 + 4 stands) guarantees best performance on high alloy grades regarding metallurgical intrinsic quality and temperature control.

The Rollmaster™ is an automation system that determines - according to the finished product - the rolling rolls, the grooves and the guides to be utilized and all the essential rolling parameters (speeds, torques, etc.).

2 PRODUCT MIX

Table 1. INPUT MATERIAL (mm)

No	types	Billet section (mm)	Billet length (mm)	Melt shop Route
1	Billet	145x145	4700	CC
2	Billet	120x120	2950 – 4700	IC
3	Slab	W150-275 / T up to 90	2300 - 4700	IC/CC

Table 2. OUTPUT MATERIAL (mm)

Product	Size Min	Size Max
Bars	12.7	76.2
Wire Rod	5.0	13.5
Flat Bars (T 8+63.5mm)	30 W	250 W
Squares	17,46	53,97
Hexagons	17,46	53,97

PRODUCTIVITY

- Reheating furnace : approximately 25 tons / hour
- Rolled material : 5,000 metric tons per month (depending on the product-mix)

STEEL GRADES

- HSS High Speed Steel
- TS Tool Steel
- SS Stainless Steel (austenitic, ferritic, martensitic, PH, duplex, super-duplex)
- VS Valve Steel (martensitic and austenitic)
- SA Specialty Alloys (Nimonic , Inconel, Maraging, Surgical Implants, etc.)

3 LAYOUT

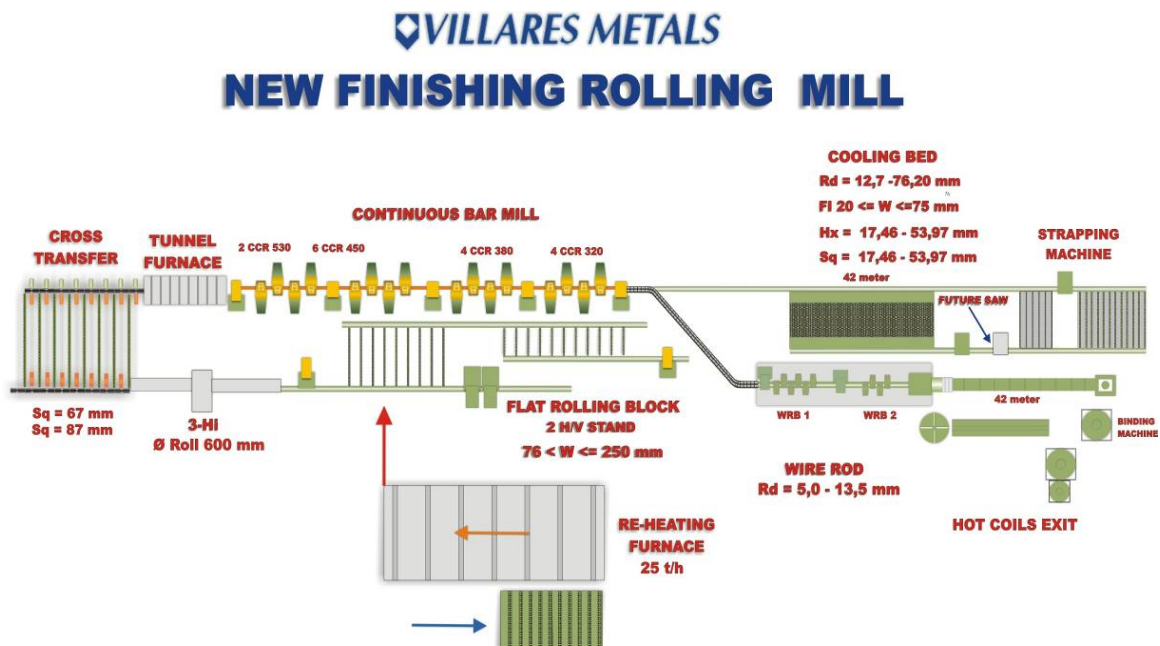

FIGURE 1 - The layout has been designed to guarantee the maximum flexibility in scheduling the rolling campaigns. The Mechanical scope comprises:

Straight Bar Line

- 16 cassette type CCR Stands
- bar measuring gauge
- 42m cooling bed
- abrasive sawing
- bundling and automatic strapping machine

Wire Rod Line

- 2 finishing mono-blocks 6+4
- bar measuring gage
- pinch roll and laying head
- ring cooling conveyor
- coil formation
- coil compacting and automatic binding machine

Large Flats Line

- 1 Flat Rolling Block (H / V arrangement)
- Future provisions for 3rd stand

Complements

- Buildings and WTP
- tunnel equalizing furnace
- fully automated scrap removal system, cross transfers, shears
- fluid and electrics and automation systems

4 MATERIAL FLOW

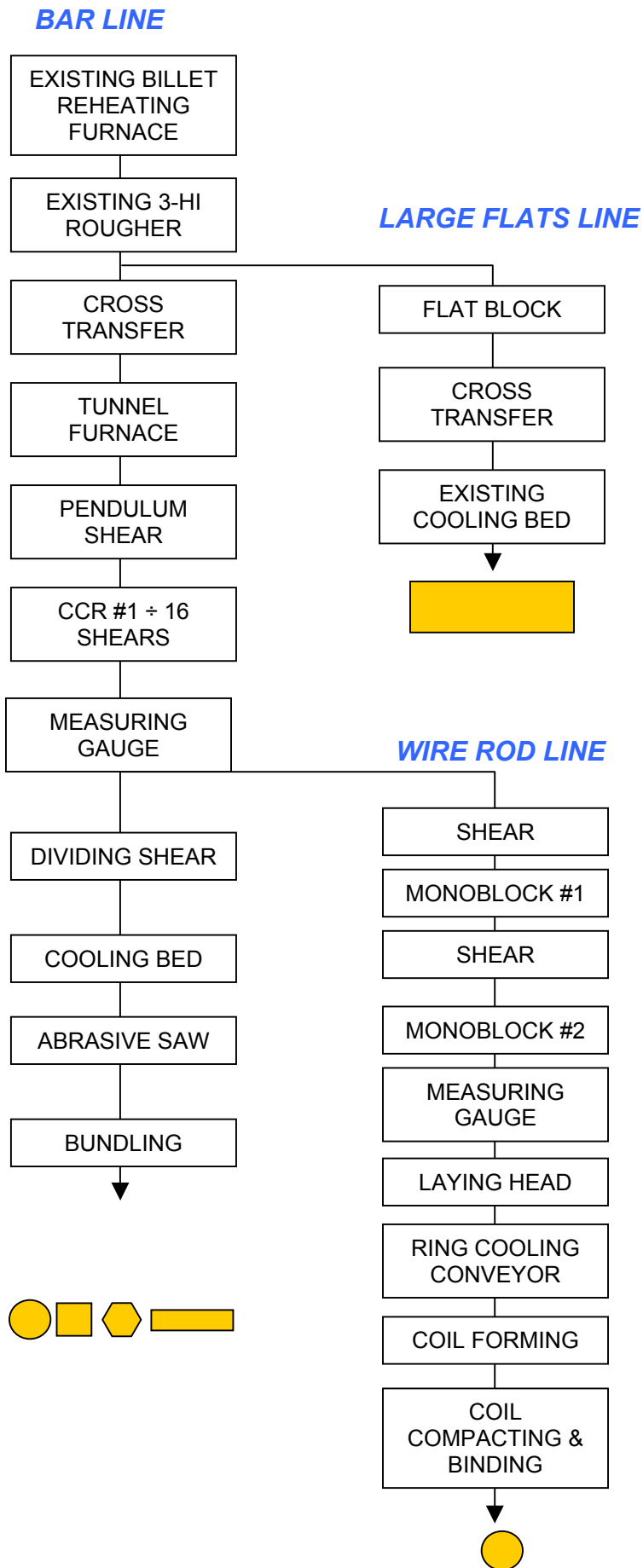

Figure 2 Material Flow -

5 CCR TECHNOLOGY IN THE BAR MILL

CCR (Cassette-type Compact Rolling) Stands provide a high rigidity, which is a must for high alloy steel grades.

Each individual stand is formed as a compact unit consisting of a gearbox and the rolling cassette clamped on it via 4 hydraulic cylinders.

CCR stands are arranged at 45° to the horizontal plane, in alternating right- and left-hand so to perform a no-twist rolling operation.

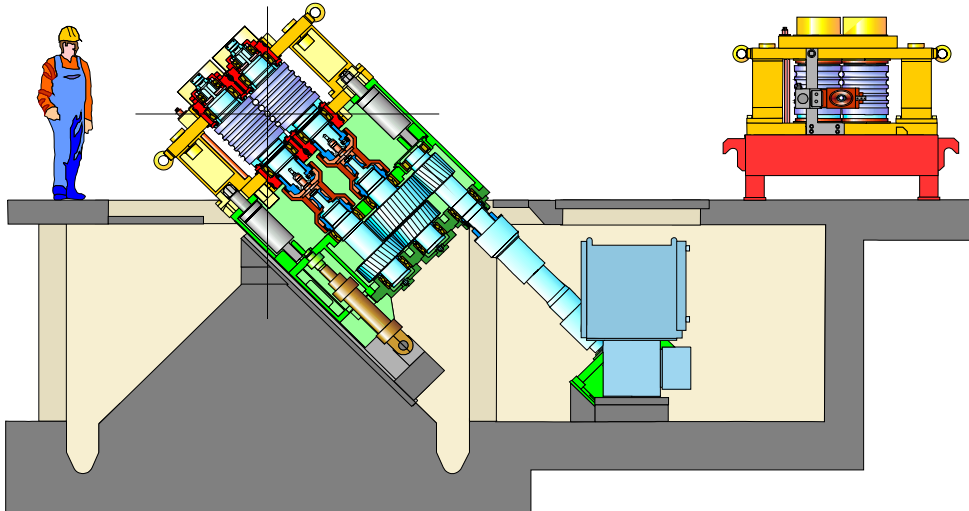

Figure 3 - CCR stands are individually shifted by a hydraulic cylinder on the base plate with sliding guides, with a position control which precisely placing the desired roll groove on the fixed pass line.

A total of 16 CCR stands are supplied, with nominal roll centerline distance ranging from 530 to 320mm, and with roll neck diameters varying from 280 to 150mm.

Roll rings are mounted onto reusable roll shafts.

A seal between gear box and rolling cassette prevents penetration of water and scale to the spindles.

Roll gap adjustment is performed by eccentric sleeves which turn simultaneously and symmetrically to the pass line. Roll centerline distance is measured by an absolute encoder.

The main components of a CCR stand are:

- Cassette with rolls and guides
- Dividing gearbox which also incorporates the final reduction step
- Gear-type self-supporting spindles between cassette and dividing gearbox
- Baseplate with sliding guides for groove positioning
- Telescopic spindle between the dividing gearbox and the reduction gearbox
- Reduction gearbox , with a bevel gear connecting to the horizontal axis motor

The main benefits offered by CCR stands are:

- High design rigidity for outstanding dimensional tolerances and product quality
- Rapid change operations, both inline for the cassette and offline for the rolls
- High degree of automation
- Flexible and efficient rolling campaigns, even for small lots
- Reduced bay height requirements
- For a given size, an identical cassette mounts on either left- or right-hand



Figure 4 - CCR (Cassette-type Compact Rolling) Stands and Standby Cassettes

6 FLAT ROLLING BLOCK (H/V) FOR WIDE FLATS

The flat block is fully CNC-controlled and comprises 2 stands with V / H arrangement, operated in reversing mode for up to 7 passes.

The flat block is able to cover the production of a large range of flats with simple and quick adjustments, as rolling is done by grooveless cylindrical rolls, and therefore for the whole range of finished sizes no roll change is necessary.

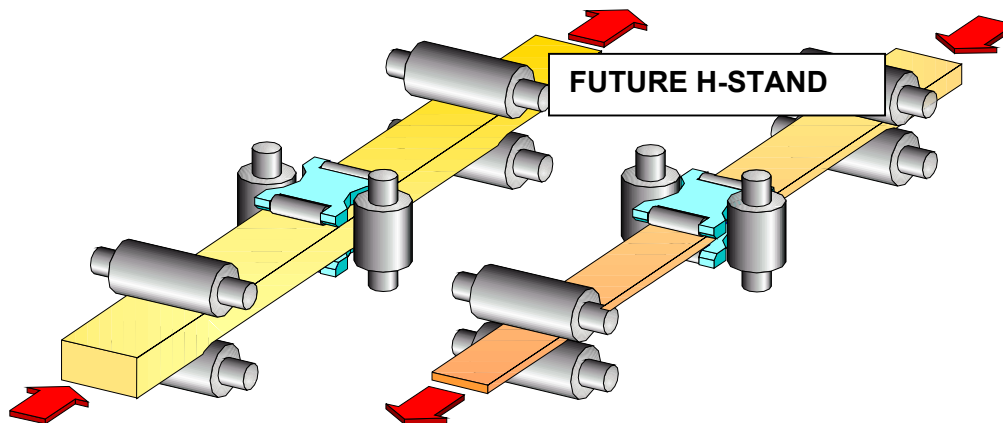

Figure 5 - The two stands are individually driven with adjustable speed, allowing to optimize the temperature profile and the output depending on the steel grade. The minimum tension control guarantees a low-tension rolling.

Roller table on both ends of the flat block feed the bar to flat block, and are hydraulically liftable to adjust to different product sizes.

Bar centering is done by aligning manipulators on both fronts of the flat block, with two movable rams which are hydraulically operated.

Guiding supports are provided on top and bottom of the vertical stand to hold the bar in flat position.

The flat rolling block is fully CNC-controlled. Roll gap and speed of each stand as automatically adjusted according to rolling program; this is generated by RollMaster software considering steel grade, dimension of starting stock and finished product, desired temperature profile.

All optimized rolling programs are stored in form of recipes, so that the operator can later pull them up and immediately initiate the rolling sequence.

The vertical stand uses rolling rings mounted on reusable shafts, while the horizontal stands uses conventional solid rolls.

The main components of Flat Block are:

- Entry / exit roller tables with aligning devices
- Vertical stand with four chocks mounted on sledges, guiding supports to hold the bar flat, combined reduction/pinion gear box with bevel gear, two universal spindles
- Horizontal stand with four chocks, roll extraction device, combined reduction/pinion gear box, two universal spindles

The main benefits offered by Flat Block are:

- Simple and robust construction
- Grooveless operation allows simple and quick adjustment
- Possibility to cover a large range of flats, with simple roll and guide adjustment and without need for roll change
- High degree of automation

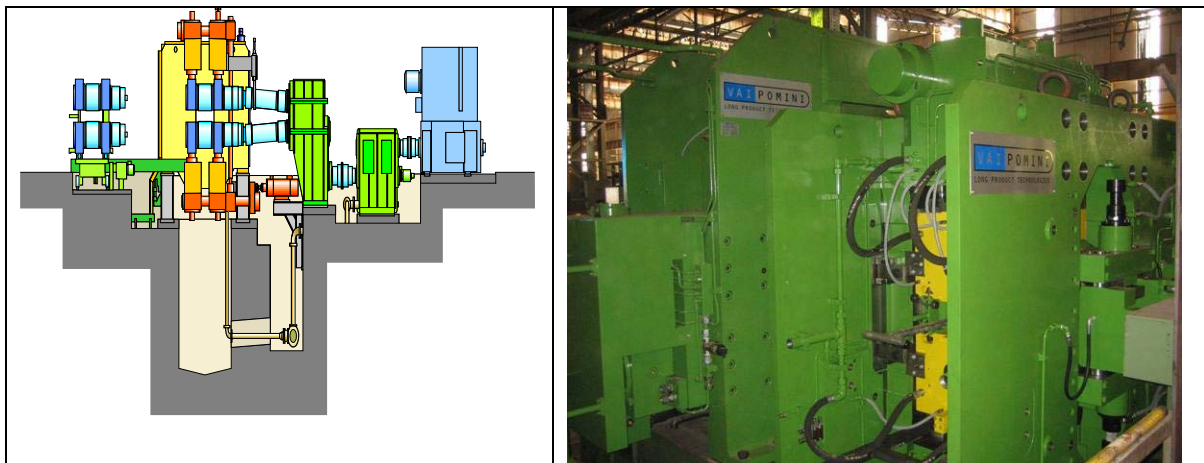

Figure 6 - Flat Block in H / V arrangement for wide flats

7 WIRE ROD LINE (MONOBLOCK IN TANDEM ARRANGEMENT: 6 + 4 STANDS)

MONOBLOCKS

The main equipment in the wire rod line are the two no-twist finishing monoblocks arranged in a 6+4 stand configuration.

This allows an optimum control of operation along the line, providing the possibility of cropping bar ends when they would tend to go excessively out of shape and / or split open; this is particularly important when rolling steel grades like stainless steels with sulfur and high speed steels.

Bar diameters from 7.5 to 11,11 mm are finished on the first monoblock, and from 5.0 to 8mm on the second one. The second block achieves a maximum speed of 50m/s at 175mm roll ring diameter.

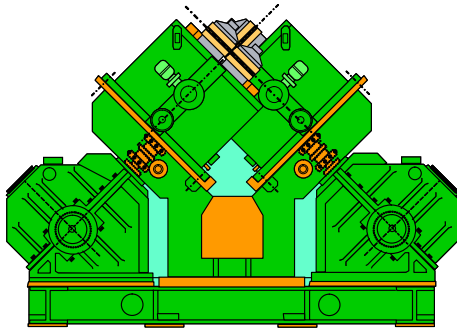
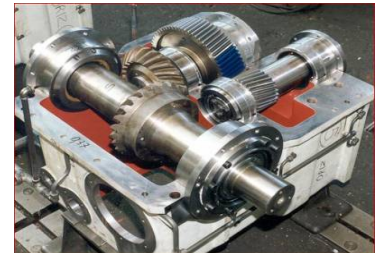

Figure 7 - The monoblocks consist of stands arranged at 90° to each other and 45° to the horizontal line, with an alternate left- and right-hand configuration. This configuration together with the symmetric roll gap adjustment provides a no-twist and fixed pass line operation.

In both hands, each stand is driven through its own mandrel / reduction group and a bevel gear mounted onto a common driving shaft. Both shafts are driven through a synchronizing gearbox by 2 AC motors. The reason behind this double-motor configuration is technical-economical, in that spare inventory is more cost-efficient (the four motors - two per each monoblock are identical). Also, smaller motors mean lower inertia and therefore easier and quicker speed adjustment - **FIGURE 8**



The main benefits offered by SVAI Monoblocks are:

- High rolling speed and high production rates
- both driving shafts are located close to foundations, which minimizes noise and vibration dimensional tolerances
- Low overall height offers improved visibility. Access for roll changing is available from both sides of the block
- Most components of all 10 stands are identical or optimized in order to reduce spares requirements. All roll rings have the same size for easier roll management
- Cantilever stand units are of modular design and are readily interchanged
- All service pipe work, bevel gearboxes and couplings located below the floor plating, to give maximum protection.

PINCH ROLL UNIT AND COIL LAYING HEAD

The pinch roll unit is situated immediately before the inclined coil laying head and is used to assist the bar in passing through the laying head. The design of the pinch roll is such that both rolls move equally to make the pinch. A bar nose end positioning system ensures that the leading end of the first ring of each coil does not snag on the cooling conveyor, but it's laid with its nose end in a trailing position

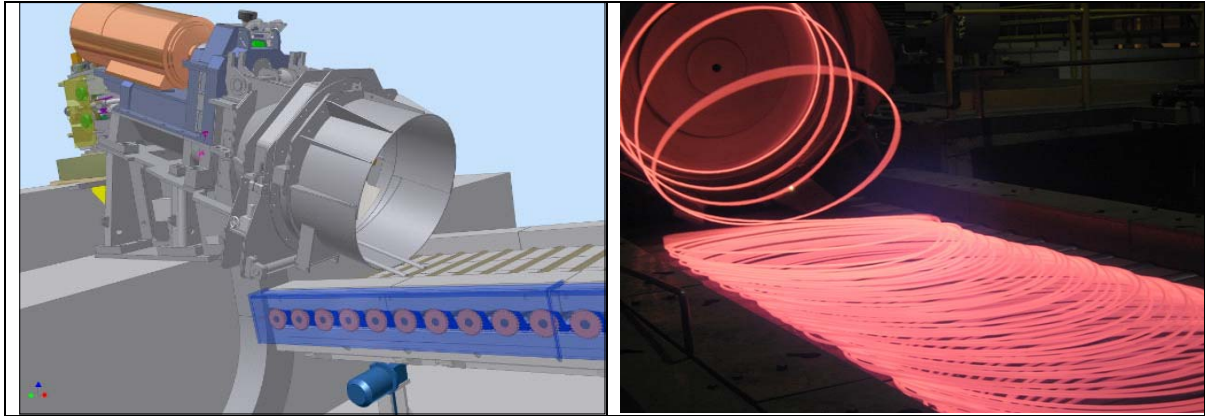

Figure 9 - Controlled Cooling Conveyor

The controlled cooling ring conveyor is a roller type conveyor arranged in separately driven sections so to minimize hot spots. It is designed to operate in three modes, according to the steel grade.

- fast cooling, using axial flow fans to blow air through the bar rings
- slow cooling, where the fans are switched off and insulated covers are brought down above the bar rings on the conveyor
- normal cooling, where the fans are switched off but the insulated covers are not used

With this design, a wide range of cooling rates is available, from 0.5 to 24°C/sec depending on bar diameter.

8 ROLLMASTER™ FOR MILL AUTOMATION AND SETUP

The RollMaster is the ideal tool for creating and managing pass schedules for reversing as well as for continuous long-product rolling mills. This well-proven software has been already applied in more than 15 mill applications.

The main features provided by RollMaster are:

- Easy computer-aided creation of pass schedules
- Calculation of material spread, mill load and bar temperature on the basis of a database containing the properties of more than 200 steel grades and special alloys
- Accurate setting of the mill guides for product-dimension changes, including print-out of the set-up protocol
- Creation of the mill set-up considering the actual condition of rolls, grooves, etc.
- Easy management of all important data related to mill grooves, guides and rolls, etc.

Additional modules are available for

- More comprehensive management in workshop of rolls and guides, with RollShopMaster tool
- Maintenance and trouble-shooting support for the mill
- Automatic groove-wear compensation

The main Benefits offered by RollMaster are:

- Easy and considerably improved pass schedule calculation on the basis of material spread, mill load and bar temperature
- Easy creation of set-up data for mill control and mechanical adjustments (e.g., guides)
- Easy introduction of new steel grades and dimensions

- No interference to ongoing rolling process due to offline creation of pass-schedules
- Increased production due to reduced mill set-up time for product-dimension or grade changes
- Improved repeatability of product characteristics and rolling process as the actual condition of the rolls and grooves is accounted for (no test billet necessary)

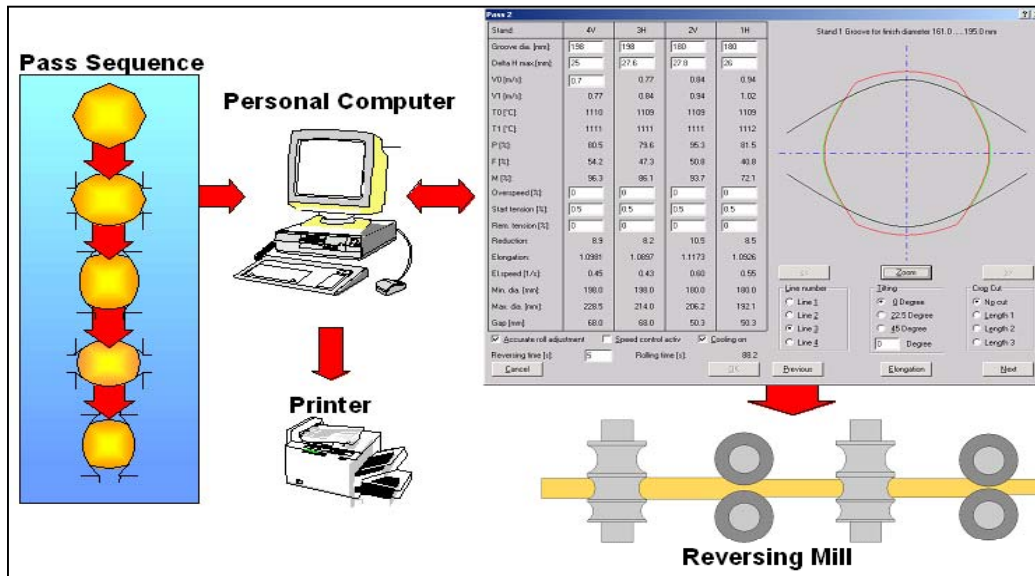

Figure 10 - RollMaster typical flowchart showing Pass Schedule Editor

9 CONSTRUCTION SCHEDULE

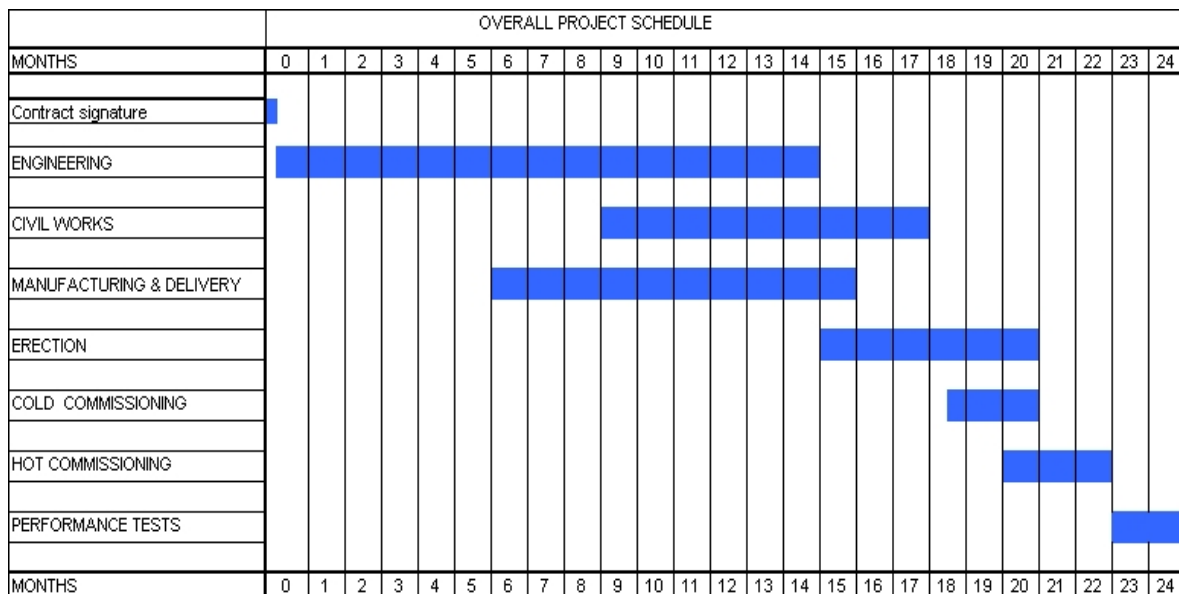

Figure 11 - Time schedule

VMSA and SVAI engineered the project in order to gear it to the requirements of :

- minimizing the impact to existing production schedule
- optimizing the turnkey concept with allocated internal and external resources
- performing parallel activities in the existing and new mill
- allowing a parallel and steady startup of the 3 different lines

- maintaining the “old” MH line active until the bar mill and flats line was started up

This parallel production on the “old” MH mill permitted VMSA to attend the high market demand of all products, whilst the new mill was installed in parallel.

6 Shutdowns with in total 67 days were spread over more than one year of construction without harming the annual production figures. Detailed planning activities and construction jobs executed around the clock during shutdowns (24 hours / 3 shifts) were the requirement for this achievement.

The milestone dates were :

- | | |
|-----------------------------|---------------|
| 1) contract effectiveness | March 2005 |
| 2) start of civil works | October 2005 |
| 3) main equipment delivered | April 2006 |
| 4) erection completed | October 2006 |
| 5) first hot rolled bar | December 2006 |

10 ADVANTAGES, BENEFITS AND RESULTS ACHIEVED

The new rolling mill provides several advantages both in terms of process and operation.

- In-time fulfillment of production and quality targets, made possible by advanced engineering and process solutions.
Steep learning curve due to technical know-how-exchange with Böhler Uddeholm sister company (BUAG / Kapfenberg) and training at reference plant in Poland (BGH Polska).
- High automation degree, for competitive operating costs.
- Fast mill conversion, for flexible production of small lots of a broad range of products.
- Low expenses for operation spares like rolls and guides.
- CCR rolling stands offer the high rigidity required for precisely rolling special steel grades, with precision and automatic setting.
- Increase of production capacity and product shapes / final dimensions.

11 CONCLUSION

The project realized at Villares / Sumaré is part of a large investment plan at Villares Metals, to increase productivity and further improve the quality of rolled material, with a cost-efficient overall operation.

From actually 84,000 tons of finished products Villares shall achieve about 110,000 tons in year 2009.

The project was assigned to Siemens VAI in consideration of its large experience as one the leading plant builders, aware that SVAI has gained sufficient expertise by installing the mill at Boehler / Kapfenberg in Austria in the nineties. Similarities between these mills made the technology exchange and the operators training easy to accomplish.

SVAI has recently started up two similar mills in the Far East region (Changwon / South Korea and Shanghai / China).

The combined technology and expertise from both companies VMSA and SVAI made possible the realization of a cutting-edge modern installation, which not only fulfills present market requirements, but is also open to further developments in order to meet future developments of high-alloy rolled long products.