

RECENT IMPROVEMENTS IN COKEMAKING DESIGN¹

Maurizio Ottria ²

Stefano Pivot ³

Ricardo Maia ⁴

SUMMARY

Making use of former ITALIMPIANTI experience, implemented through case by case cooperation with technological sources, SMS DEMAG has studied and developed highly technological engineering tools for the future coking plant. Most of them have been applied in the design of the new 45 oven LUCCHINI – Piombino battery (Italy), now under construction on a turn-key basis by SMS Demag.

The main present technological highlights of SMS DEMAG design are:

- S.A.W. - Static Analysis for the heating Wall
- H.S.H.S. - Special checkers design for heat exchange optimization
- F.A.N. - Flame Analysis for evaluation of NO_x and temperature distribution
- V.A.P. - Virtual Assembly Program for bricks design analysis
- F.A.S. - Forced Air System for combustion optimization and buckstays cooling
- CO.P.S. - Coke making Plant Simulation program for integrated systems analysis

The use of such tools allows the increasing of Coke Oven Batteries campaign life, increasing of productivity, higher automation of batteries and improvement of environmental control.

Key Words: Coke Oven battery, Design tools, Long operating life.

¹ Paper presented at the 1st International Meeting on Reduction - ABM – September, 2001 – Belo Horizonte - MG.

² Primary Area Sales Manager - SMS DEMAG SpA

³ Cokemaking Dept. Manager - SMS DEMAG SpA

⁵ Sales Engineer – Reduction Division – SMS DEMAG LTDA

SMS DEMAG IRON MAKING DIVISION

The Ironmaking Division of SMS DEMAG is the result of the merger of three major players in Ironmaking plant technology: GHH, MANNESMANN DEMAG and ITALIMPIANTI.

The capabilities of these three companies in engineering, automation, process and operation have been suitably combined into a new highly integrated organization covering this business area worldwide. Among the benefits of this integration, SMS DEMAG is now able to provide solutions based on top level proprietary technologies and processes, throughout the IRON MAKING AREA covering conventional integrated route (raw material handling, sintering, pelletizing, coke ovens, B.F.) and alternative route (coal based DRI, Redsmelt®). (Fig. 1).

The Ironmaking Division, with competence centers in Germany, Italy, USA and Brazil, stands for leading know-how and future oriented solutions based on decades of experience in plant and machinery construction, these being developed in the constant exchange of experience with its Customers.

In Brasil, SMS DEMAG have built a powerful and flexible engineering organization, SMS Demag LTDA, capable to operate with equal efficiency either in small or large projects.

Fig. 1

SMS Demag: A RELIABLE PARTNER

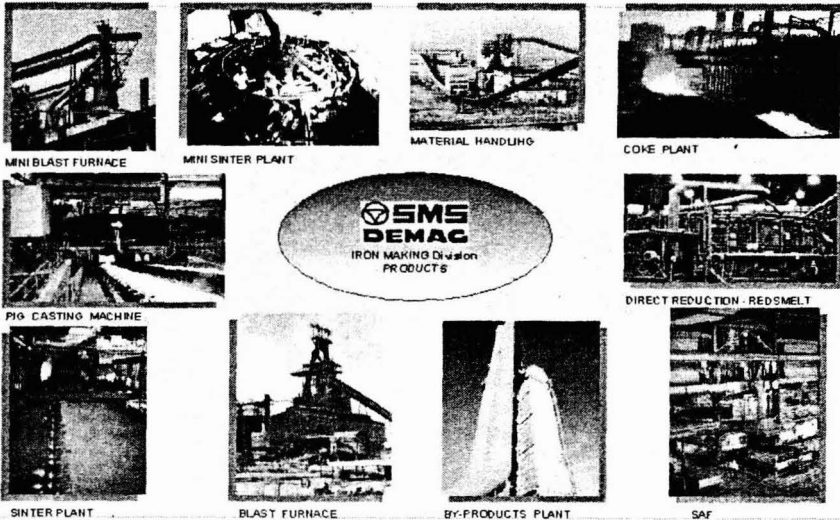

RECENT IMPROVEMENT IN COKE MAKING DESIGN

The in-house highly and constant qualitative production of coke is an essential factor to achieve top performing BF operation.

This aspect, along with the need of lowering coke production cost and consequent enlargement of coal supply sources and new stringent environmental standards to comply with, brought to new technologically advanced battery design.

The key-point for the success is to design and realize coking plants that can guarantee:

- Smooth long life operation
- Safe long-life from environmental point of view
- Technological updating

The Ironmaking division of SMS Demag, incorporates the experience gained as Italmimpianti in coke making plant design (Fig. 2) and is presently strongly engaged in this field: to this purpose have been studied and developed highly technological engineering tools for the future coking plant design. Most of them have been applied in the design of the new 45 oven LUCCHINI – Piombino battery, in the frame of the important order awarded to SMS Demag in 2000.

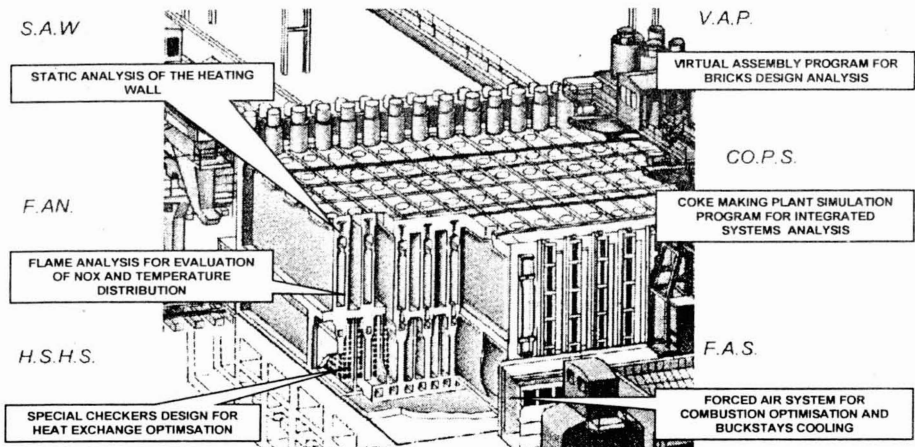

Fig. 2

Fig. 3 summarize the main present technological highlights of our design:

- S.A.W. - Static Analysis for the heating Wall
- H.S.H.S. - Special checkers design for heat exchange optimization
- F.A.N. - Flame Analysis for evaluation of NO_x and temperature distribution
- V.A.P. - Virtual Assembly Program for bricks design analysis
- F.A.S. - Forced Air System for combustion optimization and buckstays cooling
- CO.P.S. - Coke making Plant Simulation program for integrated systems analysis

Fig. 3



➤ **S.A.W. Static analysis of the heating wall**

The main goal of the static analysis, due to the use of different coal sources during the distillation, is to verify the effect of the different forces acting on the heating wall structure during the entire process cycle. (Fig. 4).

The main goal of the studies performed on the checker brick is to:

- optimize checkers dimensions
- minimize the coking time.

The H.S.H.S. (High Specific Heating Surface) is the special checker that has been designed to obtain maximum thermal efficiency in the aim of optimizing both fuel consumption and regenerators volume. (Fig. 5).

GOAL:
*to verify the oven structure for
different swelling pressures*

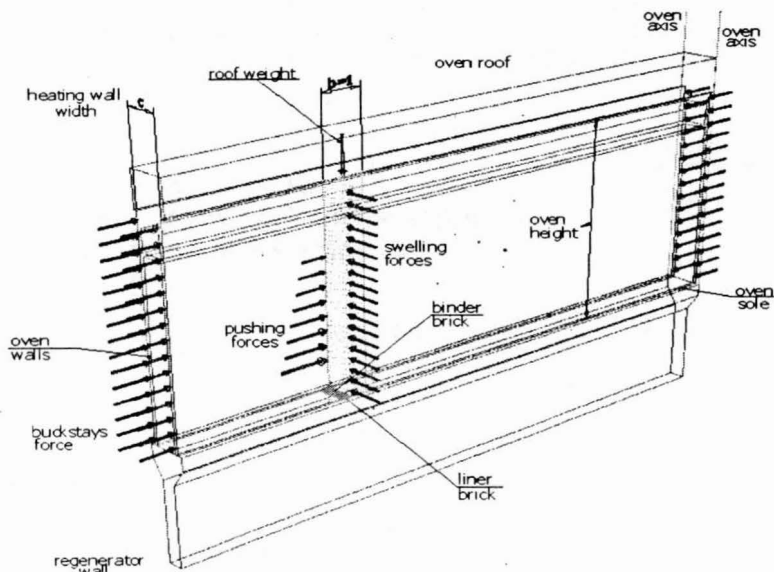
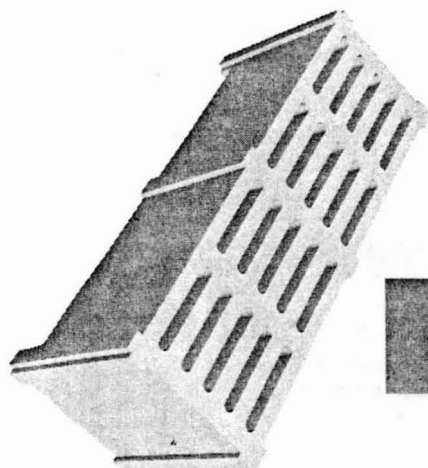

Fig. 4



GOAL:
*to optimize checkers dimensions and
optimize thermal efficiency*

"HSHS"
SPECIAL CHECKERS DESIGN WITH HIGH
SPECIFIC HEATING SURFACE FOR
MAXIMUM THERMAL EFFICIENCY

Fig. 5

F.A.N. – Flame Analysis

The main goal of the flame analysis (Fig. 6) is:

- to verify the temperature distribution on the heating wall
- to verify the NO_x emissions

The simulation has been performed through FLUENT package, one of the most widely used software for Computational Fluid Dynamics.

GOAL:
to verify the Heating Wall temperature distribution & NO_x emissions

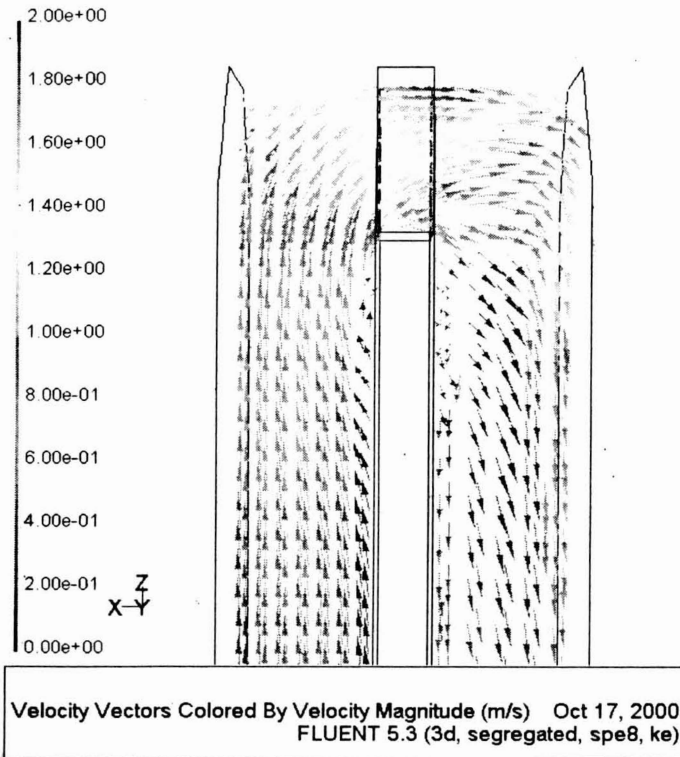

Fig. 6

➤ **V.A.P. Virtual Assembly program**

The Virtual Assembly Program has been developed with a special add-on of the Pro/ENGINEER software. Pro/E is one of the most widely used mechanical design software programs in the world. Our V.A.P. tool is the first application of PRO/E to the cokemaking plants. (Fig. 7).

The main goal of the Virtual Assembly Program is to:

- avoid erection interference
- verify bricks dimensions and design

In the picture we can see the virtual assembly and the actual one taken from the pre-assembling activity in the bricks supplier 's manufacturing shop.

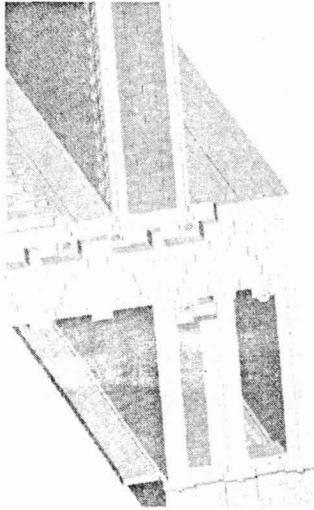

GOAL:

to avoid erection interference verifying bricks dimensions and design

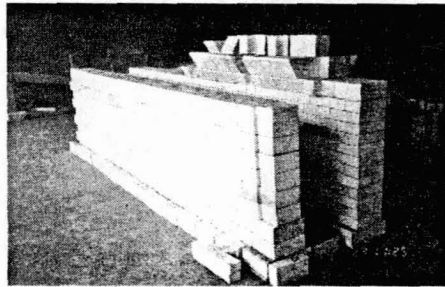

Fig. 7

"VAP"

VIRTUAL ASSEMBLY PROGRAM

➤ **F.A.S. Forced Air System (Fig. 8)**

The forced air system has been designed for two main objectives:

- to optimize combustion
- to guarantee the mechanical characteristics of buckstays through air cooling system

The latter system is covered by patent application.

Goal: to optimize the combustion and to guarantee mechanical characteristics of buckstays. Under patent application

F.A.S.

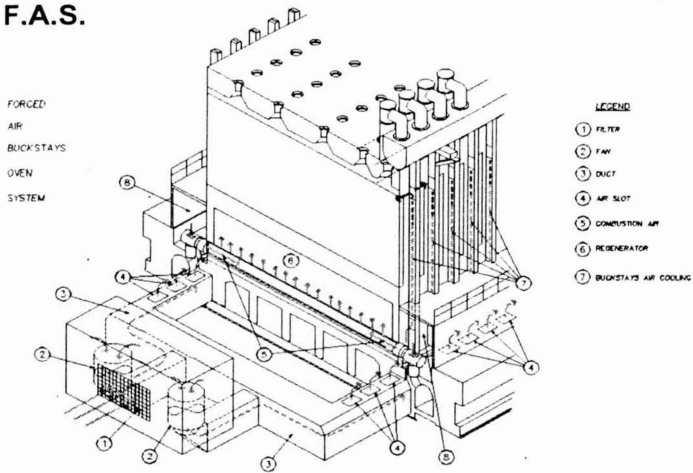

Fig. 8

The CO.P.S. Coke Making Plant Simulation

The Coke Making Plant Simulation is a software tool that is used to analyze the whole cokemaking plant, aiming at achieving the best operational efficiency.

It takes into account the plant configuration, the timing of the process sequence, the logistical constraints.

The outcome is used to individuate possible bottlenecks in the plant and/or to study an improved scheduling system of the plant. (Fig. 9).

GOAL: to analyze complex systems

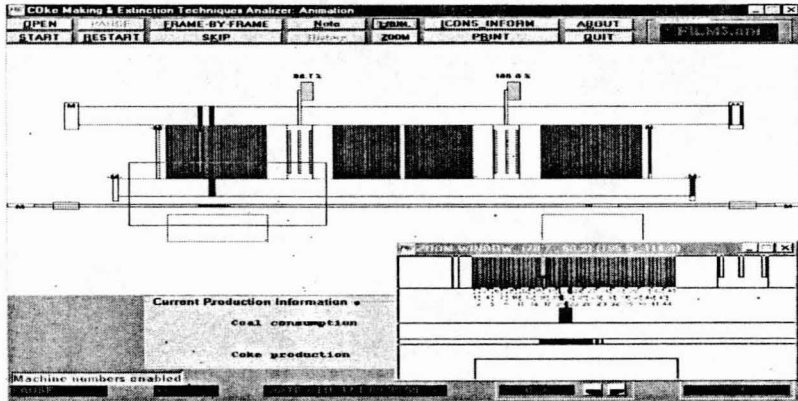

Fig. 9

"COPS" Coke Oven Plant Simulation System

CONCLUSIONS

The experience of former Italmimpianti and the recent improvements in coke making design, are the basis for the project of the new coke oven battery in Piombino-Italy, now in execution by SMS Demag Italmimpianti Division, a reliable partner in coke making plant design and construction.

