

# TECHNOLOGY HIGHLIGHTS FOR A NEW 20-HIGH STAINLESS STEEL MILL<sup>1</sup>

Jörg Knauth<sup>2</sup>

## Abstract

Description of the electrical equipment and advanced drive & technology solutions for the new 20-High Stainless Steel Mill of ThyssenKrupp Nirosta at Krefeld/Germany. By utilizing DTC (direct torque control) rolling mill drives, advanced control technologies based on a one-controller concept and Aspect Object technology, the solution is tailored to meet the high-performance requirements of the most modern cold rolling mill in the world. Beside various thickness control features the technology includes also model-based pass schedule and set-up using mathematical models. The object-based system allows for the total integration of controllers and the Human System Interface and access to all system information through one operator portal. The application sets the world standard for the automation of cold rolling mills by taking advantage of ABB's Industrial<sup>IT</sup> conception in order to fulfil highest quality and productivity demands in the stainless steel industry. The modular system configuration concepts of drives and automation was decisive for the successful commissioning and start of production with in such a short period of time. Providing an integrated automation and diagnosis system helps the customer to keep a high level of production and improvement potential.

**Key words:** New automation concept; Drive system; Improved thickness tolerances.

<sup>1</sup> Paper presented at 42<sup>th</sup> Rolling Processes, Rolled and Coated Products Seminar of ABM; Santos, SP, October 25 to 26, 2005.

<sup>2</sup> Product Manager Cold Rolling Mills, ABB Automation GmbH, Germany

## **Project Survey**

### **Advanced drive and automation technology**

For the new stainless-steel mill of ThyssenKrupp Nirosta in Krefeld, Germany, ABB has provided a complete solution based on latest technologies.

Within the scope of the project, ABB was responsible for project management, engineering, erection and commissioning.

The scope of supply included the complete electrical and automation equipment:

- Complete process control equipment, incl. technological controls and adaptive preset models
- Production management system
- Main and auxiliary drive systems using the latest AC technologies on medium and low voltage levels.
- Instrumentation and power supply

### **16 months to first coil**

Together with their consortium partner Sundwig GmbH, which was responsible for the mechanical layout and supply of the plant, ABB succeeded in starting the plant ahead of the deadline agreed upon in the contract due to a smooth project execution. Following a construction time of only 16 months, the plant was ready for commissioning in early 2004.

The required quality characteristics were achieved after only a few coils and 3-shift production was introduced at the beginning of March 2004.

Due to the short commissioning time, the rolling mill has already exceeded the planned production of cold rolled strip by more than 14,000 t.

With their new plant at Krefeld, ThyssenKrupp Nirosta now runs five cold rolling mills – in 1994 ABB already delivered the complete electrical equipment for cold rolling mill no. 4.

**Figure 1.** Main Operator Cabin: View of the mill stand during automatic roll change

## Technological Highlights

### World class standards for rolling mills

ABB sets high technology standards for the automation of rolling mills in general and specifically for stainless-steel stands.

For this cold rolling mill, ABB applies the complete 800xA automation concept with advanced technologies ranging from auto-adaptive preset models for presetting the rolling mill, technological controls for achieving the quality parameters, right up to production management drive and process control technology.

These types of solutions for cold rolling mills are applied to all types of mills and processing lines for high-grade steel, mild steel and for non-ferrous metals.

The success of the concept is based mainly on 3 important components of the electrical equipment, which will be described on the following pages.

- Automation of technological processes like thickness control, utilizing a new controller and featuring powerful diagnosis functions
- Self-adapting models for the preset of the mill, integrated into the production management system
- Use of drives technology

All of the drives and the automation system are highly modular and use only a minimum number of different parts. Easy maintenance and diagnosis.

Materials	Stainless steel
Capacity	110,000 t/a
Strip width	max. 1350 mm
Coil weight	max. 30 t
Coil diameter	max. 2300 mm
Entry thickness	max. 5 mm
Exit thickness	min. 0.2 mm
Rolling speed	max. 800 m/min
Strip tension entry	30 ... 500 kN
Strip tension exit	30 ... 500 kN
Start up	03 /2004

Figure 2. Plant data

### Technological controls

The solution package for the 20-high roll stand consists of the following technological control concepts:

- Thickness control based on mass flow and speed/tension/thickness feed forward controls, superimposed to the monitor control
- Direct tension control and coil eccentricity compensation
- Flatness control (crown adjustment, skewing, axial shifting, roll gap position)

The figure gives an overview of the control concept of the main control loops for thickness and tension.

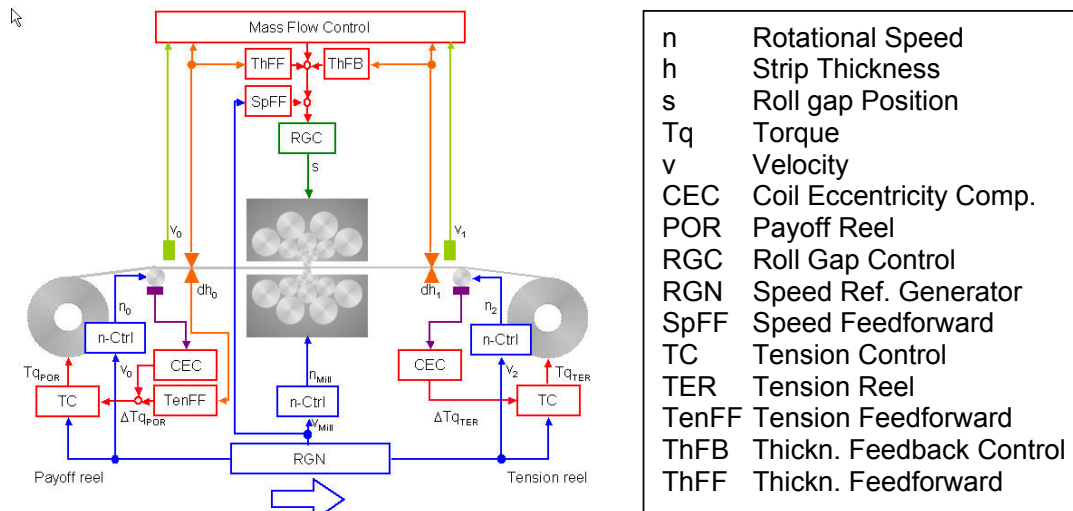

**Figure 3.** Control concept for the 20-high mill.

### Roll gap control

For the roll gap control two basic modes, either gap position or total roll force, can be applied. Selection of mode depends on the type of superimposed Automatic Gauge Control (AGC) and the threading strategy applied. To ensure a constant response time over the whole working range various process related adaptation and supervision functions are included in the software modules and performed online to rolling process.

### Thickness feedback control

The basic control strategy is thickness feedback control (monitor control) based on the measured thickness deviation at the exit side of the mill. The delay time, transport of the strip from the roll gap to the thickness gauge, essentially determines the control system's dynamic response, particularly at low rolling speed. The software package includes a predictive model based solution to improve the dynamic behavior of the thickness feedback controller significantly. Monitor control is always active and hot stand-by to be ready for a bumpless switchover in case of sensor failure.

### Thickness feed-forward control

By using the thickness gauge at the entry side of the mill stand the thickness feed-forward control is able to compensate for thickness deviations caused by changing entry thickness. A correction value is calculated according to a stored entry thickness deviation and forwarded to the roll gap control for interaction when the strip section reaches the roll gap.

### Mass flow control

Using the mass flow principle, the outgoing strip thickness at the instant of rolling can be computed from the incoming strip thickness and the entering and exiting strip speeds. By means of this mass flow control concept, high control accuracy can be achieved. Therefore it clearly enhances the concepts of thickness feedback and thickness feed forward influencing product quality.

**Speed feed-forward control**

Online speed feed forward control provides the capability to compensate velocity depending process variations, especially in phases of acceleration and deceleration of the mill.

**Tension feed-forward control**

Tension feed-forward control responds to entry thickness deviations and adjusts the coiler torque accordingly in order to consider the interactions between roll gap and tension.

**Coil eccentricity control**

Coil eccentricity compensation minimizes periodic tension oscillations generated by changes in the circularity of the coil. The major reason for this is that the strip head is clamped in the slot of the mandrel. Tension torque corrections are applied at each revolution when the diameter change passes the contact zone of the strip on the coil.

**Flatness control**

Homogeneity of stress distribution and material shape is controlled by the flatness system. The flatness error, given as difference between the measured strip flatness and the target curve, are minimized by modifying the roll gap with various control functions, such as crown adjustment, roll gap skewing, cooling patterns and eccentric positioning control. The influence of each separate type of control action is defined by evaluated action curves. A least square fit of these action curves to the flatness error results in the most efficient combination of control actions needed to reduce the flatness deviation. The actuator control loops receive correction values to be applied to the preset setpoint values.

**Control strategy and integration**

The individual control strategies described above include monitoring functions for safe operation. If a sensor (e.g. laser) fails the control strategy will be automatically changed in order to continue production. At any time manual operations such as set-point changes or selection and de-selection of control loops can be performed smoothly.

Due to the fact that the phenomena in the roll gap during rolling are highly non-linear and time-varying, ABB uses adaptive controllers to detect changes and disturbances in the system and modify the parameters accordingly. For this purpose quality and stability criteria for the entire control loop are taken into account.

Due to the integration of this technological concept into ABB's proven and robust system, particularly the relationships between strip thickness, tension, rolling speed and flatness can be taken into account for parameter setting to achieve a high quality of the strip.

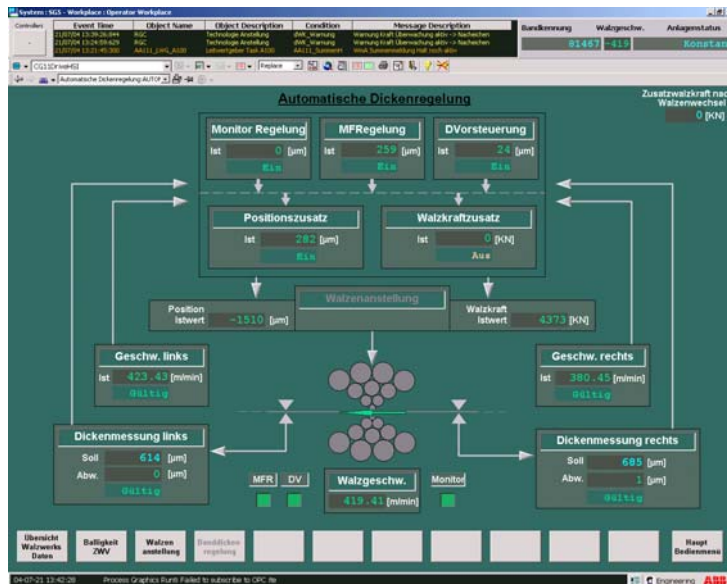

Figure 4. Operator screen for technological controls

### Mathematical models for Presetting

The use of mathematical models for preset calculation permits accurate specification of the setpoints for the rolling mill on the basis of the current process conditions and the properties of the incoming material. The calculations are based on models, which take the varying physical conditions during reduction into account, so that the highest level of accuracy is achieved for setpoint generation in the rolling mill.

Feedback of the measured values during operation adapts the model to the short-term (process changes) or long-term changes (changes in the material types).

In combination with the Pass Schedule Optimization and Set-up of the Production Management System supplied they minimize threading, tail-out and reversing times as well as reduce off-gauge length at the strip head and tail.

### New process controller

This automation solution uses the new, fast controller, which has excellent communication properties and was designed for the special requirements of cold rolling mills and processing lines.

The modular and flexible controller is used in rolling mills for simple control tasks as well as for highly sophisticated technological controls. All plant control functions can be implemented by using only one type of controller for:

- Mill drive control
- Pilot and coordination control
- Technological control
- Plant control for entry, exit and mill section
- Media supply control

The control software and the programming tool allow the functionality to be designed, tested and debugged in offline mode. The new or modified application is downloaded into the assigned controller(s) and a bumpless changeover to the new or modified part of the application is performed automatically by the controller. This process takes place in the background while the applications are running.

The structure of the control software is based on an object-oriented way using ABB's Aspect Objects™ technology, which means that changes made to an object type or instance thereof – at any hierarchical level – only affect that type (and all of its instances) or that instance only. For this reason, subsequent bug fixes, updates, improvements, expansions etc. can be performed quickly and easily by so-called incremental downloads that only affects the part changed.

The tool can be fully integrated alongside the Process Operation tool Operate<sup>IT</sup> as an Aspect System, allowing seamless navigation from the runtime environment to the configuration environment. With a click of the mouse you can go from the process flow representation of a plant section to its control program, to examine and even edit it. All solutions are equipped with a simulation functionality and displays to enable testing of the solution without a process or controller being connected.

The documentation of the library and the corresponding functionality is included in the online help of the Control Builder Professional.

- ❑ DIN-rail mounted, self cooling/no fan
- ❑ Vast I/O expandability, hot-swap I/O
- ❑ Programming languages according to IEC 61131-3 standard
- ❑ C-code layer for the process models and adaptations
- ❑ Libraries from binary to technology
- ❑ Multiple simulation capabilities for off-line testing without target controller
- ❑ On-line functions such as program changes, signal force, status inspection, etc.
- ❑ Fibre-optic communication with drives, I/O system and between the AC800 controllers

**Figure 5.** Features of new controller for metals applications.



**Figure 6.** View of the Control Builder, Function plan representation acc. to IEC61131

## Production planning and management

In order to meet the high productivity requirements of the plant the solution applied to the 20-high mill is equipped with a Production Management System. The following functions have been integrated into the production control system:

- Order planning and management
- Material tracking
- Model-based pass scheduling and setpoint generation
- Quality data management
- Strip defect tracking
- Roll management, data exchange with roll change robot
- Coil and production reports

The screenshot shows a software dialog box titled 'Sichplan Detail'. It contains several input fields for production parameters and a data table.

**Input Fields:**

- Stichplan Name: USE03745
- Variante: 1
- Nummer: 4301
- Variante: 60
- Auslaufdicke [mm]: 1.19
- Einlaufdicke [mm]: 0.4
- Walzdicke [mm]: 1.19
- Total Reduktion [%]: 66.39
- Anzahl Stiche: 8
- Gewicht [kg]: 19189
- Breite [mm]: 1260
- 1. Walzenwechsel: 8
- 2. Walzenwechsel: 8
- Kurve Code: 1
- Kurve Amplitude: 0
- Arbeitsvorgang: 350

**Data Table:**

Stich Nr.	Sep. Kraft [kN]	Dicke Einlauf [mm]	Dicke Auslauf [mm]	Red. Abs. [%]	Red. Rel. [%]	Zug Einlauf [kN]	Zug Auslauf [kN]	Walz Geschw [m/min]	Konus Pos upper	Konus Pos lower	Öl Fluss Einlauf	Öl Fluss Auslauf	Kronen Pos 1	Kronen Pos 2	Kronen Pos 3	Kronen Pos 4	Kronen Pos 5	Kronen Pos 6
1	3652	1.19	0.98	17.98	0.21	100	258	500	0	0	2300.00	1800.00	0.00	0.00	0.00	0.00	0.00	0.00
2	3577	0.98	0.83	14.96	0.15	258	226	800	0	0	1300.00	800.00	0.00	0.00	0.00	0.00	0.00	0.00
3	3681	0.83	0.71	14.46	0.12	226	199	800	0	0	1300.00	800.00	0.00	0.00	0.00	0.00	0.00	0.00
4	3813	0.71	0.62	12.68	0.09	199	175	800	0	0	1300.00	800.00	0.00	0.00	0.00	0.00	0.00	0.00
5	3750	0.62	0.55	11.29	0.07	175	154	800	0	0	1300.00	800.00	0.00	0.00	0.00	0.00	0.00	0.00

Buttons: Drucken, Schließen

Figure 7. Dialog detail of the pass schedule of a coil

## Advanced drive technology

The main mill drives for the two coilers and the stand are equipped with ABB's IGCT semiconductor-based medium voltage converters of the type ACS6000. The auxiliary AC drives are equipped with low voltage frequency converters of the type ACS600.

ABB drive control is based on the patented Direct Torque Control DTC concept, providing dynamic performance in terms of torque and speed accuracy.

The superior performance of the drives has a direct impact on the process performance, since the drives are one of the main actuators for strip tension and rolling speed when it comes to high strip quality.



The fast response to torque variations allows a better accuracy in the strip tension control of the tension reel. The high torque accuracy and dynamics of the drives used in combination with mass flow control leads to extremely fast correction times of process disturbances and hence to exceptional thickness quality.

**Table I.** Data of the AC main drives

Mill stand	4168 kW 360 / 1100 rpm
Uncoiler/tension reel	4000 kW each 340 / 1320 rpm

## Results

The tight integration of the control functions of the drives and the automation system as well as ABB's automation technology concept ensure that the following targets are reached:

- Highest quality tolerances for all products
- Constant qualities
- Increased mill productivity, thanks to higher rolling speed and improved acceleration and deceleration.

## Thickness results

Figure 8 gives an example of the exit thickness deviation (scaling is per micrometer) in the lower chart over the complete pass and the upper chart shows the rolling speed with max. of 400 m/min.

The exit thickness remains stable at around  $\pm 1$   $\mu\text{m}$  at an exit thickness of  $h_{\text{exit}}=490$   $\mu\text{m}$  in the last pass. Due to the control strategies applied the deviation stays within the same window at acceleration and deceleration phases, even at low speeds.

Figure 9 gives an impression of the influence of the eccentricity control on the exit thickness deviation at constant speed. When the additional torque (3<sup>rd</sup> chart from top) is zero, compensation is switched off and the tension variation at the exit section increases. (second chart from top).

With compensation switched on, additional torque values are generated and applied to the upcoiler, reducing the tension variation in the exit strip and leading to reduced peaks in the deviation of exit thickness, even thickness deviation is already at very precise level (<0.5 % of nominal thickness)

## Availability

As the mill is equipped with highly reliable systems in the drives and automation section the electrical equipment has a large share in the overall availability of the plant. The total availability as a system of electrical and mechanical equipment is unrivalled. The highly modular medium voltage drive ACS6000 is used for the drive system. It uses the same size and type of modules for the inverters and the incoming supply of the incoming busbar for all 3 main drives. Due to modularity and fuse-less design of the drive system the equipment can be easily maintained keeping downtime low in case of failure.

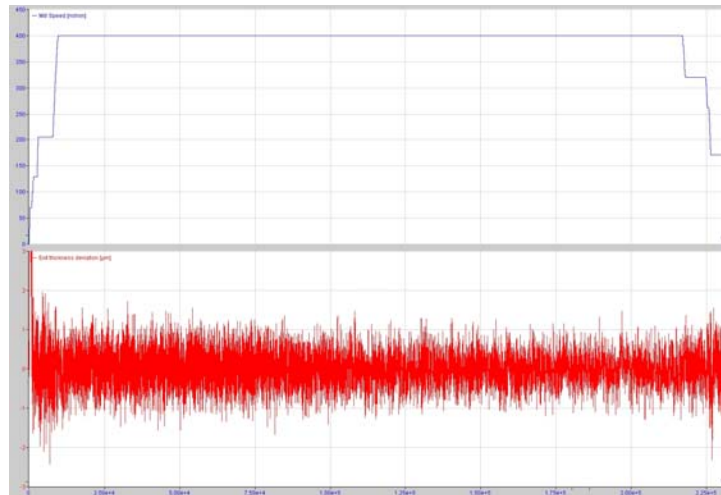

**Figure 8.** Thickness deviation,  $h_{\text{exit}}=490\mu\text{m}$ , last pass

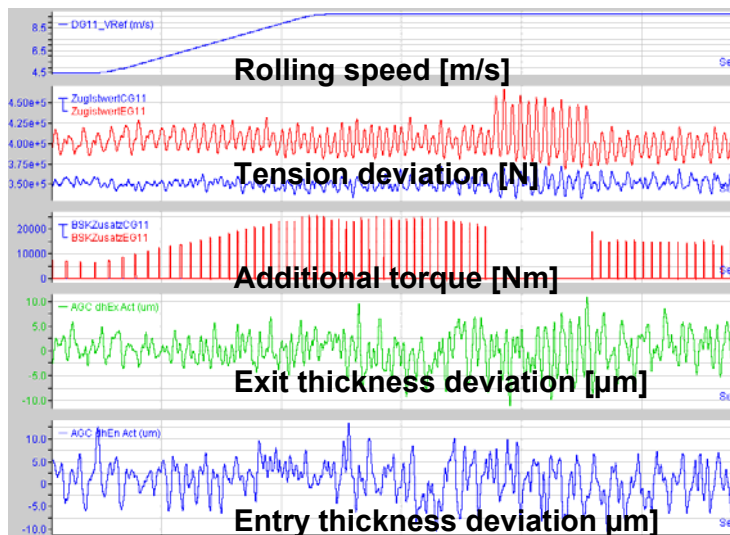

**Figure 9.** Eccentricity compensation reduces exit tension and thickness deviation

The same principle is applied to the automation part: one type of controller for all functions, one type of process I/Os for >98% of the I/Os, the same I/Os for the drives and the automation section and a consistent system of PC servers and clients used for process control.

With this concept the number of different spare parts can be kept to a minimum.

To keep downtime low in case of faults the system features a superb diagnosis system based on the Aspects-Objects™ process operation tool Operate<sup>IT</sup>.

## REFERENCES

- 1 Press Release Magazin „Stahl und Eisen“, Germany, Issue 8/2004, “ThyssenKrupp Nirosta: Neues 20-Rollen-Kaltwalzgerüst mit technischen Highlights“
- 2 ABB Brochure, Success Story on Project
- 3 “Advanced technologies for a new 20-roll mill stand”, ABB Automation GmbH, No. DEPI/BM 0902 EN 01.05
- 4 Project Guidelines and Documentation ABB

# DESTAQUES TECNOLÓGICOS PARA UM NOVO LAMINADOR 20-HIGH PARA AÇOS INOXIDÁVEIS<sup>1</sup>

Jörg Knauth<sup>2</sup>

## Resumo

Descrição dos equipamentos elétricos, soluções de inversores de frequência e tecnologias avançadas para o novo Laminador 20-High para aços inoxidáveis da ThyssenKrupp Nirosta em Krefeld, Alemanha. Através da utilização do DTC (controle de torque direto) para inversores de frequência aplicados a Laminadores; de tecnologias avançadas de controle baseadas no conceito de um controlador-único e na tecnologia voltada a objetos, a solução é personalizada de encontro aos requisitos de alta performance dos Laminadores a Frio mais modernos do mundo. Além das várias características do controle de espessura, a tecnologia incluiu também modelamento do plano de passes e modelos matemáticos. O sistema baseado em objetos permite uma total integração dos controladores e da Interface Homem Máquina e acesso a todas as informações do sistema através de um portal do operador. A aplicação estabelece novos padrões mundiais para automação em Laminação a Frio, tirando vantagens do conceito Industrial<sup>IT</sup> da ABB de modo a preencher os mais altos requisitos de qualidade e produtividade na indústria de aço inoxidável. O conceito de configuração de sistema modular dos inversores e automação foi decisivo para o comissionamento e início de produção em um curto espaço de tempo. O fornecendo um sistema de automação com diagnostico integrado ajuda o cliente a manter um alto nível de produção e potencial de melhorias.

**Palavras-chave:** Novo conceito de automação; Sistema de inversores de frequência; Melhoria nas tolerâncias de espessura

<sup>1</sup> *Contribuição Técnica ao 42º Seminário de Laminação Processos e Produtos Laminados e Revestidos; 25 a 28 de Outubro de 2005, Santos, SP, Brasil.*

<sup>2</sup> *Gerente de Produtos para Laminação a Frio, ABB Automation GmbH, Alemanha*