

LAYER THICKNESS MEASUREMENT OF INSULATION COATING ON ELECTRICAL STEEL BY MESACON F2800EL LAYER THICKNESS GAUGE¹

Detlef Jährling²
Wolfgang Pilz³

Abstract

Laminated cores based on electrical steel (silicon steel) are used for transformers or rotors and stators of electrical motors. The base material of the cores is coated with an insulation varnish to increase the electrical resistance, the eddy current resistance and to protect them against corrosion. Also the endurance of the punching machines/tools is hardly influenced by the quality of the coating. The coating process is done in a continuous process before cutting and punching of the single parts of the core. The thickness of the insulation layer is very important for the quality of the core. In the past isolation materials like paper were used but resulted in a bad stacking factor and limited the maximum temperature of the core. Nowadays, mainly coatings related to the AISI classes C3, C5 and C6 are used. The benefits of any manual or automatic coating process control highly depend on the measurement accuracy of the layer thickness gauge. This publication concentrates on information about the MESAcon F2800EL layer thickness measuring system, the improvement of customers coating process and customers benefits and experience.

Key words: Silicon steel; Electrical steel; Insulation coating; Process improvement.

¹ *Technical contribution to the 50th Rolling Seminar – Processes, Rolled and Coated Products, November, 18th to 21st, 2013, Ouro Preto, MG, Brazil.*

² *President, MESAcon Messelektronik, Gostritzer Straße 67a, Germany*

³ *Dr. Product manager, MESAcon Messelektronik, Gostritzer Straße 67a, Germany*

1 INTRODUCTION

A highly constant coating over the whole width and length of the material to be produced is required. In case upper or lower limits of the coatings are exceeded; the stacking factor or the resistance are influenced. Such over-coating as well as weakness in the electrical resistance of the coating can be drastically reduced by using the Mesacon F2800 layer thickness measuring system. Former measurement systems, even based on the same general measuring principle, were not able to measure the full production program with a reliable accuracy. Mesacon's task was to design the new F2800EL based on the already existing F2800 system but with the capability to measure the full production program of a silicon steel coating line.

2 MATERIAL AND METHODS

2.1 Measuring Principle and Basic System Design

The Mesacon F2800 is a layer thickness measuring gauge based on the beta backscattering principle. The isotope source emits a constant beta ray beam that is backscattered by the surface layer material. The backscattered radiation results in a current due to the ionization process inside the high stable ionization chamber. This current is amplified to an adequate signal for further data processing. Considering a determined calibration curve of the measured layer, the corresponding value for the layer thickness is calculated.

To avoid any influence of different kinds of base material; the F2800 system is equipped with a base measuring system.

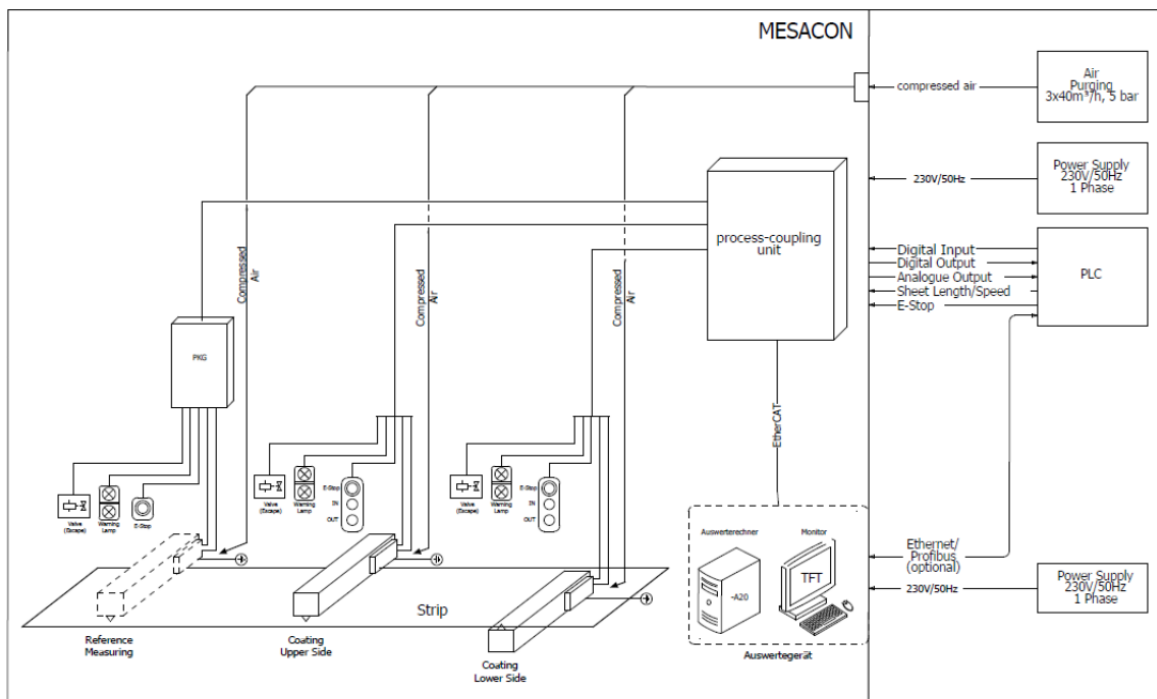

Figure 1. F2800EL configuration.

1. Base material measurement with rotating device or linear unit;
2. Coating measurement upper side with linear unit
3. Coating measurement lower side with linear unit
4. On site control buttons / lamps

5. Process Coupling Unit / Connection to Line Automation System
6. HMI

2.2 Sensor and Mechanical Layout

A linear moving unit designed for 24/7 operation is used for the scanning movement of the sensor. Mounting bracket with samples for zero adjustment and calibration is included. System operates in full automatic mode without any action of the operator.



Figure 2. F2800EL mechanics configuration.

1. Sample holder for calibration and zero adjustment
2. Linear unit for sensor operation
3. Backscatter sensor

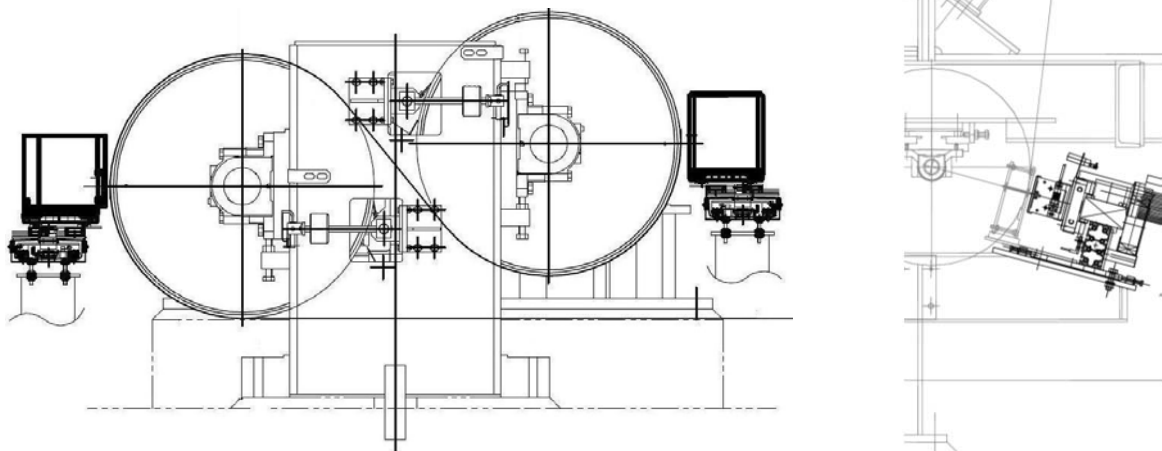

Figure 3. F2800EL installation example.

1. Top and bottom measurement installed at set of S-rolls or deflection roll
HMI Visualization

The flexibility of the Mesacon F-Series software allows the full adaption of HMI for operation, maintenance and offline reporting. Visualization and interfaces can be adapted to any line and the different design and capabilities of the coater itself.



Figure 4. F2800EL configuration.

1. Thickness length profile
2. Thickness cross profile
3. Current gauge scanning position
4. Current thickness as bar graph
5. Current thickness in digits
6. Indication of safety status
7. Coil data

3 RESULTS OF INDUSTRIAL OPERATION

3.1 Overview

Using F2800EL layer thickness measurement system grants benefits for electrical steel producer as well as for their customers:

1. Reduced consumption of insulation
2. Reduction of manual measurements based on the reliability of the on line measurement for the applied insulation coatings.
3. Optimization of stacking factor for transformers and electrical motors
4. Less complaints for material out of specification

The first F2800EL system was installed at ThyssenKruppElectrical Steel in India in 2010. In 2011 the next system was installed at CD-Wälzholz in Germany. Customer's main target was to have a measurement system with a high reliability for organic and semi-organic insulation layers. In the past, the production counterchecked every produced coil manually. After installation and optimization of the F2800EL system the manual work of the production could be reduced.

Based on the non-disclosure agreement Mesacon has no allowance to provide detailed information about the variation in used layers and the measuring results. But customer's satisfactory certificate for the first application and the placed order for a further complete system for his second line highlights the capability and reliability of the F2800EL system.



SATISFACTORY CERTIFICATE / ZUFRIEDENHEITS-ZERTIFIKAT

<u>Contact Person / Ansprechpartner</u> Andreas Hügelmann; ahuegelmann@cdw.de +49 (2331) 964 2251	
<u>Project description</u> Continuous Coating Line (CCL) for electrical steel coating with organic or semi-organic insulation layer. Measurement of layer thicknesses between 0.5µm and 10µm with Mesacon F2800 coating layer gauge at three measuring points. Operation with Prometium 147 isotope sources for the beta-backscattering-principle.	<u>Projektbeschreibung</u> Lackbeschichtungsanlage im Konti-Betrieb zur Beschichtung von Elektroblech mit organischer oder teil-organischer Isolationschicht. Messung der Schichtdicken von 0,5µm bis 10µm mit Mesacon F2800 Schichtdickmessgerät in drei Messpositionen. Einsatz von Prometium 147 Isotopenquellen für Beta-Rückstreu-Verfahren.
<u>Installation position</u> 1. Reference gauge in entry of the line 2. Top side gauge in exit of furnace 3. Bottom side gauge in exit of furnace	<u>Installationsposition</u> 1. Basismessung im Einlauf der Linie 2. Bandoberseite hinter Trockenofen 3. Bandunterseite hinter Trockenofen
<u>Commissioning date / Inbetriebnahmedatum</u> 28.12.2011	

Huegelmann 28.12.2011
 Place, Date / Ort, Datum

[Signature]
 Company Sign./Stempel | Unterschrift, Stempel
 CD Wälzholz
 Prometium 147 Beta-Rückstreu-Verfahren

Figure 5. Satisfactory certificate.

4 DISCUSSION

Based on our customer's feedback and our developments we confirm following results of using F2800EL system:

- Reduced amount and frequency of manual measurements Increased homogeneity of layer thickness
- Optimized endurance of the punching machines/tools
- Safe system operation by internal tracking system for each coil

The Mesacon F2800EL system is a part of Mesacon's software and data base development. This allows the customer to get all new developments directly for his system.

Beside of a general coating line layout every line is slightly different. In the discussion with the customer and based on our experience the best measuring position can be

found. This allows us to determine the optimum for performance as well as for line maintenance. F2800EL mechanics can be adapted and modified for easy change of the rolls of the line.

The production and delivery of the system is attended from the early beginning by our consultancy until final optimization and customers training. The partnership between the customers and MESAcon is the basis for our development and a constant availability and system performance.

5 CONCLUSION

MESAcon F2800 paint / varnish measurement system was enhanced to an insulation layer thickness measurement system F2800EL with the capability to reliably measure the very thin layers for the full production portfolio of the customer down to 0.5µm. By replacing systems from other suppliers based on the same measuring principle the customers reached the possibility to minimize the consumption of insulation coating. Beside of the reduced amount of coating the layer thickness can be kept on a constant low level by keeping all relevant resistant data of the insulation. This allows the optimization of the stacking factor for the manufacturers of transformers and electrical motors.