

CREEP EVALUATION AT 200 MPA OF MARAGING 300 ALLOY¹

Adriano Gonçalves dos Reis²
Danieli Aparecida Pereira Reis³
Carlos de Moura Neto⁴
Antônio Jorge Abdalla⁵

Abstract

Maraging steels are well-known for their outstanding combination of strength, fracture toughness and machinability. However, data available on the mechanical properties of maraging steel at elevated temperature are very few and specialized applications of the steel occasionally demand short-time exposures at unusually high temperatures and it is desirable to have data on the creep behavior of the material during such service conditions. Constant load creep tests were conducted in a Maraging 300 steel at 200 MPa. Creep tests were conducted on a standard creep machine at temperature range of 550°C to 650°C. Samples with a gage length of 18.5 mm and a diameter of 3 mm were used for all tests. The material shows good resistance against creep at 550°C and 600°C. However, at 650°C, the material exhibits an increasing tendency to creep that can be associated to the reversion of martensite to austenite at this temperature.

Key words: Creep; Maraging steel; High temperature.

¹ Technical contribution to 68th ABM International Congress, July, 30th to August 2nd, 2012, Belo Horizonte, MG, Brazil.

² Chemical engineer. MSc., Doctor Degree Student, Instituto Tecnológico de Aeronáutica (ITA), São José dos Campos, SP, Brazil.

³ Chemical engineer. Dr., Teacher and Researcher, Universidade Federal de São Paulo (UNIFESP), São José dos Campos, SP, Brazil.

⁴ Metallurgical engineer. Dr., Teacher and Researcher, Instituto Tecnológico de Aeronáutica (ITA), São José dos Campos, SP, Brazil.

⁵ Mechanical engineer. Dr., Teacher and Researcher, Instituto de Estudos Avançados (IEAV/DCTA), São José dos Campos, SP, Brazil.

1 INTRODUCTION

The need for alloys with ultra-high strength combined with adequate toughness led to the development of a class of low-carbon high-nickel steels, known as 18Ni Maraging steels. These steels are based on the Fe-18%Ni binary alloy with additions of various alloying elements such as cobalt, molybdenum, titanium and aluminum for precipitation hardening. The alloys are termed “maraging” because they possess a martensitic microstructure when annealed, and attain their ultra-high strength on being aged in the annealed or martensitic condition. The grades of these steels are denoted by numbers such as 200, 250, 300 or 350, the number specifying the level of the yield strength in ksi that can be obtained in the steel with appropriate heat treatments.⁽¹⁾ Maraging steels evoked tremendous interest, especially in the aerospace world, when their development was announced in 1959. The solid-propellant rocket motor program by NASA (National Aeronautics and Space Administration) sparked the considerable research and development that has been conducted to take advantage of the many fine properties of these steels.⁽²⁾

Though considerable work has been carried out in the past in generating data on the mechanical properties of lower grades, only limited information is available in the open literature on the mechanical properties of 300 grade.⁽³⁾ Data available on the mechanical properties of Maraging steels at elevated temperature are very few and most of the studies on the low grades were confined to tensile properties or stress-rupture studies up to 540°C.^(1,4) Specialized applications of the steel occasionally demand short-time exposures at unusually high temperatures and it is desirable to have data on the creep behavior of the material during such service conditions.

In this work the creep behavior of a 300 grade commercial Maraging steel are evaluated by carrying out creep tests according to ASTM E-139-06, at temperature range of 550°C to 650°C and 200 MPa. The parameters as the primary creep time (t_p), steady state creep rate ($\dot{\epsilon}_s$), final creep time (t_f), final strain (ϵ_f) and reduction of area (RA) are determined, considering that are important to evaluate the creep resistance of the material.

2 EXPERIMENTAL PROCEDURE

Material was provided in bars by a co-operation work of Eletrometal (currently GERDAU) and DCTA/IAE (Departamento de Ciência e Tecnologia Aeroespacial / Instituto de Aeronáutica e Espaço). Chemical composition of the Maraging Steel 18Ni 300 is in accordance with AMS 6521 A (1983). The material was submitted to thermal treatment at temperature of 820°C for 1 hour to solubilization (Figure 1). The heat treatment was conducted at IAE/DCTA, using a Brasimet Koe 40/25/65 furnace.

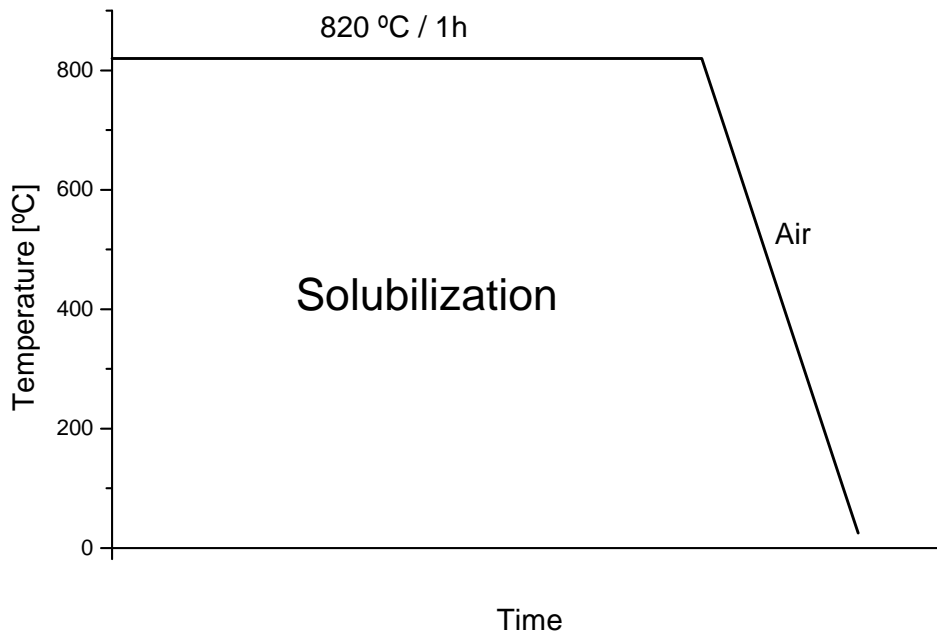

Figure 1. Solubilization heat treatment before creep tests.

After the solubilization, the specimens have been hot-forged with dimensions and shape show in Figure 2, according requested by ASTM E139 standard.⁽⁵⁾

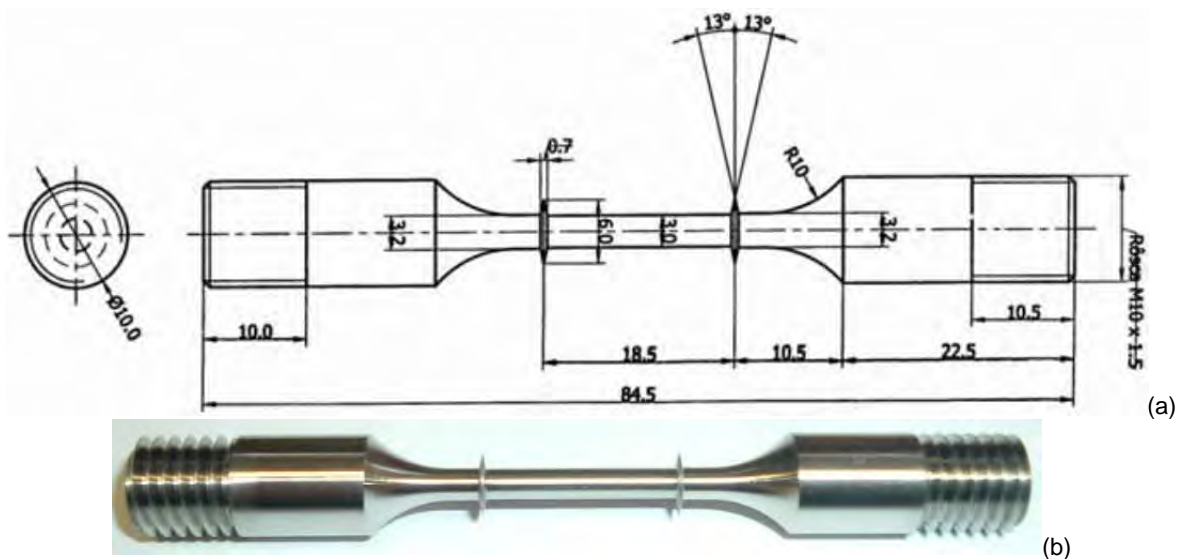

Figure 2. Creep specimen: (a) dimension and shape and (b) image of the Maraging 300.

Constant load creep tests were conducted with a Maraging 300 alloy at 200 MPa. Creep tests were conducted on a standard creep machine at temperature range of 550°C to 650°C. Samples with a gauge length of 18.5 mm and a diameter of 3 mm were used for all tests. Creep tests were performed according to ASTM E139 standard.⁽⁵⁾

3 RESULTS

Representative creep curves at 200 MPa are showed in Figure 3.

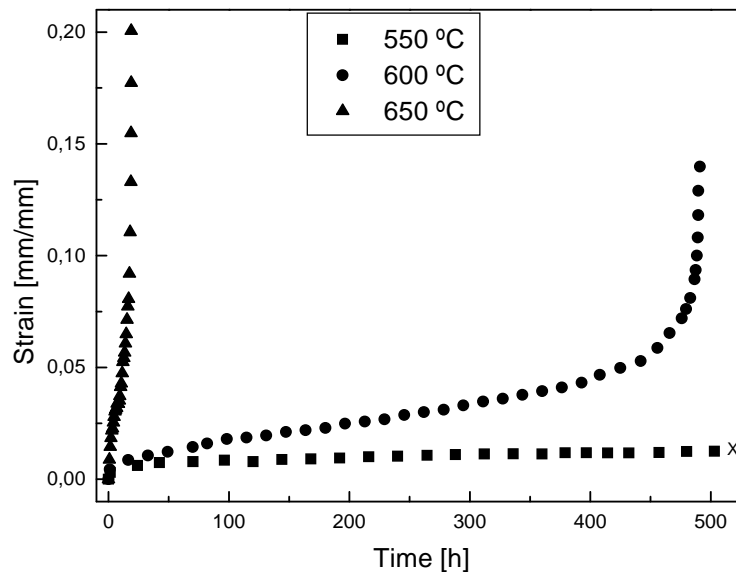

Figure 3. Creep curves at 200 MPa and 550°C to 650°C.

Results from the creep tests at 200 MPa are summarized in Table 1, which shows the values of stress (σ), primary creep time (t_p), secondary creep rate ($\dot{\epsilon}_s$), final creep time (t_f), final strain (ϵ_f) and reduction of area (RA). The creep test at 650°C was interrupted at 1,152 h, and only t_p and $\dot{\epsilon}_s$ can be calculated.

Table 1. Creep data at 200 MPa

σ (MPa)	Temperature (°C)	t_p (h)	$\dot{\epsilon}_s$ (1/h)	t_f (h)	ϵ_f (mm/mm)	RA (%)
200	550	264.55	3.03×10^{-6}	-	-	-
	600	16.00	8.41×10^{-5}	491.00	0.1399	39.67
	650	1.33	3.23×10^{-3}	18.75	0.2005	46.22

Figure 4 shows the specimens before and after creep tests at 200 MPa and different temperatures.

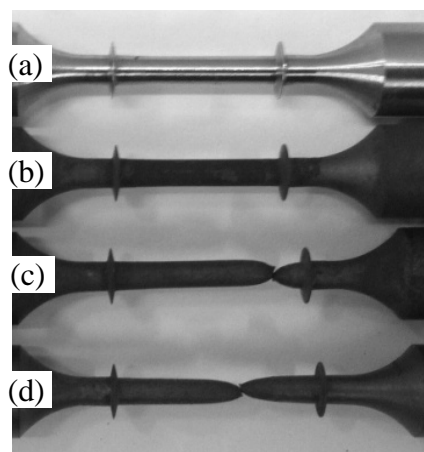

Figure 4. Maraging 300 specimens: (a) before creep tests and crept at 200 MPa and (b) 550°C (1,152 h), (c) 600 °C (491 h) and (d) 650 °C (19 h).

4 DISCUSSIONS

Figure 3 shows that most of the creep life of this alloy is dominated by a constant creep rate that is thought to be associated with a stable dislocation configuration due to recovery and hardening process.⁽⁶⁾ From Figure 4 it can be observed the increase of ductility when increasing the temperature. The decrease of final strain (ϵ_f) and the increase of reduction of area (RA) are associated with the temperature increases presented at Table 1, and it confirms the higher ductility of the alloy. The material shows good resistance against creep at 550°C and 600°C, as can be inferred from the near horizontal shape of the curves from Figure 3 and lower steady-state creep rate from Table 1. However, at 650°C, the material exhibited a lower creep resistance. It is known that the secondary creep rate ($\dot{\epsilon}_s$) increases and final creep time (t_f) decreases with increasing temperature since the temperature dependence of creep rate is normally well represented by an Arrhenius equation.⁽⁶⁾ But in addition to that, the strong reduction to creep life can be associated to the reversion of martensite to austenite at 650°C. When 18%Ni Maraging steels are heated for extended periods of time at high temperatures, the martensite matrix tend to revert to austenite by diffusion-controlled reaction.^(7,8) The extent of reversion depends on the time and the temperature, and 50% of reversion to austenite can be obtained by heating 1 hour at 650°C.⁽²⁾ Literature reports the strong impact of increasing creep rates at temperatures above 600°C in 18% Ni Maraging steels 250 and 350 grades.^(1,4)

5 CONCLUSIONS

Constant load creep tests were conducted with a Maraging 300 alloy at 200 MPa and temperature range of 550°C to 650°C. The alloy has showed a typical creep behavior with the three stages. Most of the creep life of this alloy is dominated by a constant creep rate that is thought to be associated with a stable dislocation configuration due to recovery and hardening process. The secondary creep rate has increased with increasing test temperature, following the Arrhenius equation. Temperature of test at 650°C has shown a strong increase of creep rate, reducing significantly the time of rupture due to creep. This phenomenon can be associated with the reversion of martensite matrix to austenite.

Acknowledgment

The authors acknowledge the Brazilian research agencies CNPq (Proc.nº 141274/2013-1) and FAPESP for financial support.

REFERENCES

- 1 VISWANATHAN, U. K.; KUTTY, T. R. G.; KESWANI, R.; GANGULY, C.. Evaluation of hot hardness and creep of a 350 grade commercial maraging steel. *Journal of Materials Science*, v.31, p. 2705-2709, 1996.
- 2 SLUNDER, C.J. and HALL, A. M. The metallurgy, behavior, and application of the 18-percent Nickel Maraging steels – A survey, Battelle Memorial Institute, NASA SP-5051, 1968.
- 3 RACK, H. J. Age Hardening-Grain Size Relationships in 18Ni Maraging Steels. *Materials Science and Engineering*, v.34, p. 263-270, 1978.

- 4 GUREWITZ, G.; ATZMON, N.; ROSEN, A. Creep and stress relaxation in 18% Ni (250) maraging steel. *Metals Technology* v.4, p. 62-65, 1977.
- 5 Annual Book of ASTM Standards, in "American Society of Testing and Materials". Standard practice for conducting creep, creep-rupture and stress-rupture tests of metallic materials. (Philadelphia, PA, 1995) 03.01, 257-267.
- 6 EVANG, R. W.; WILSHIRE, B. *Introduction to Creep*. United Kingdom: Oakdale Printing Company LTD, 1993.
- 7 DAVIS, J. R. *Heat-Resistant Materials*. United States of America: ASM Specialty handbook, 1997.
- 8 PARDAL, J. M.; TAVARES, S. S. M.; CINDRA FONSECA, M. P.; ABREU, H. F. G.; SILVA, J. J. M. Study of the austenite quantification by X-ray diffraction in the 18Ni-Co-Mo-Ti maraging 300 steel. *Journal of Materials Science*, v. 41, p. 2301-2307, 2006.