

IMPROVED GRINDING CIRCUIT PERFORMANCE WITH THE DERRICK® STACK SIZER™ SCREEN¹

Steven B. Valine²
Jobe E. Wheeler³
Laercio G. Albuquerque⁴

Abstract

The high capacity Stack Sizer screening machine consists of up to five decks positioned one above the other and all operating in parallel. Together with urethane screen surfaces as fine as 75 microns (200 mesh), fine wet screening has become a practical reality in mineral processing operations worldwide. The application of this technology to improve the performance of closed circuit grinding is demonstrated with specific application examples.

Key words: High frequency screens; Grinding; Comminution; Classification.

MELHOR DESEMPENHO DE CIRCUITO DE MOAGEM COM A PENEIRA DERRICK® STACK SIZER™

Resumo

A peneira Stack Sizer de alta capacidade consiste de no máximo cinco decks posicionados um sobre outro e todos operando em paralelo. Juntamente com malhas de polyuretano tão finas quanto 75 micra (200 mesh), o peneiramento úmido fino torna-se uma realidade mundial em operações de processamento mineral. A aplicação dessa tecnologia para melhorar o desempenho de circuitos fechados de moagem é demonstrada em quatro exemplos específicos.

Palavras-chave: Peneiras de alta freqüência; Moagem; Comminuição; Classificação.

¹ Technical contribution to the 41th International Meeting on Ironmaking and 12^h International Symposium on Iron Ore, September 12 – 16, 2011, Belo Horizonte, Vila Velha, ES.

² President-Separation Technology Group, Derrick Corporation, Buffalo, NY, USA.

³ Product Application Manager, Derrick Corporation, Buffalo, NY, USA.

⁴ Sales Manager-Latin America, Derrick Corporation, Buffalo, NY, USA.

1 INTRODUCTION

Screening is the process of separating particles by size and fine screening typically refers to separations in the range of 10 mm (3/8 inch) to 38 microns (400 mesh). Fine screening, wet or dry, is normally accomplished with high frequency, low amplitude, vibrating screening machines with either elliptical or straight-line motion. Various types of wet and dry fine screening machines and the factors affecting their operation have been discussed previously.⁽¹⁾

In fine particle wet screening, the undersize particles are transported through the screen openings by the fluid and the fraction of fluid in the slurry will therefore affect the efficiency of the separation. From a practical standpoint, the feed slurry to a fine screen should be around 20% solids by volume to achieve reasonable separation efficiency. As most of the fluid passes through the screen openings rather quickly, the fine screening process can be completed in a short screen length. Therefore screen width, rather than screen area, is an important design consideration for fine wet screening.

Recognition of this concept led to the development of multiple feed point fine wet screening machines. For example, the Multifeed screen consists of three screen panels mounted within a rectangular vibrating frame and is actually three short screens operating in parallel. Each screen panel has its own feed box and the oversize from each panel flows into a common launder and then to the oversize chute. Similarly, the undersize from each of the three panels flows into the undersize hopper. The popular 1.2 m (4 ft) wide by 2.4 m (8 ft) long version has a total effective width of 3.0 m (10 ft). In general, multiple feed point machines have been shown to have 1.5 to 2 times more capacity than a single feed point machine of equivalent size and screen area.

2 ADVANCES IN TECHNOLOGY

2.1 Stack Sizer Screening Machine

Expanding further on this concept, the Stack Sizer screening machine was introduced in 2001. With a capacity considerably greater than any other type of fine wet screening machine previously available, the Stack Sizer has up to five vibrating screen decks operating in parallel for a total effective width of 5.1 m (17 ft). As shown in Figures 1 and 2, the decks are positioned one above the other and each deck has its own feed box. A custom-engineered single or multiple-stage flow distribution system is normally included in the scope of supply to representatively split the feed slurry to each Stack Sizer screen and then to the decks on each machine. Ample space is provided between each of the screen decks for clear observation during operation and easy access for maintenance and replacement of screen surfaces. Each screen deck, consisting of two screen panels in series, is equipped with an undersize collection pan which discharges into a common launder with a single outlet. Similarly, the oversize from each of the screen decks collects in a single hopper with a common outlet. Two Super G[®] vibrating motors rated at 1.9 kW (2.5 HP) each and rotating in opposite directions produce a uniform high frequency linear motion throughout the entire length and width of all screen decks for superior oversize conveyance.

As mentioned above, the fluid passing through the openings carries the undersize particles through the screen openings. The screening process is essentially complete

when most of the fluid has passed through the openings. Any remaining undersize particles adhere to the coarse particles and are misdirected to the oversize product. An optional “repulping” system is available for the Stack Sizer in which spray water is directed into a rubber-lined trough located between the two panels on each deck. With this feature, oversize from the first panel is reslurried and screened again on the second panel. This repulping action maximizes the correct placement of undersize particles and its use will depend upon the particular objective of the screening machine.



Figure 1. One of 38 Stack Sizer screening machines operating at an iron ore mine in Brazil.

To date, over 800 Stack Sizer screening machines are in operation at mineral processing plants worldwide. Dry mass flow capacity typically ranges from 100 to 350 t/h. This is roughly equivalent to 3 or 4 of the older style Multifeed screens discussed above. Like all screening machines, capacity depends upon many factors such as screen panel opening, weight recovery to oversize, the amount of nearsize particles, particle shape, and slurry viscosity.

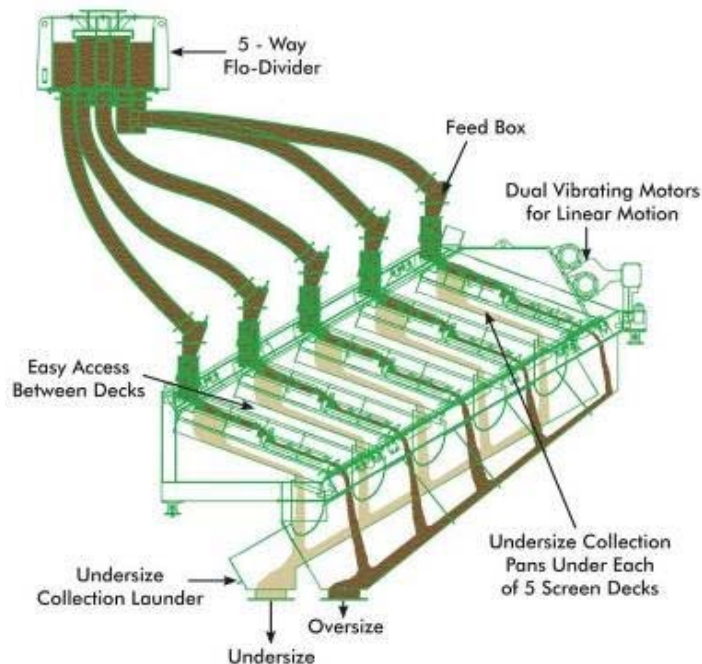

Figure 2. Principle of operation.

2.2 Polyurethane Screen Surfaces

The availability of high open area, long wearing polyurethane screen surfaces with openings as fine as 75 microns (200 mesh) has made fine wet screening more feasible than previously thought possible. In the past, plant designers typically avoided the use of fine screens due their relatively low capacity, the high consumption rate of woven steel wire screen panels, and the tendency of these types of panels to blind with nearsize particles. This view has now changed as demonstrated by the following case studies describing process improvements through the use of Stack Sizer screening machines and fine urethane screen surfaces in place of conventional particle classification equipment.

3 CASE STUDIES

As an introduction to these four case studies which all describe the use of fine screens in closed circuit grinding, it is interesting to note that research work over many decades has supported the concept of closing grinding circuits with screens. In 1925, E. W. Davis at the University of Minnesota Mines Experiment Station conducted closed circuit grinding tests with a rake classifier, a screw classifier, and a screen. He concluded that the use of screens would result in higher mill capacities with less overgrinding.⁽²⁾ Other studies concluded with statements such as “lower grinding costs are possible with screen circuits”⁽³⁾ and “the master key for great improvements in capacity and in energy consumption in closed grinding circuits in improved sharpness of classification”.⁽⁴⁾ A recent presentation on flowsheet development for the planned Essar Steel iron ore concentrator project in Minnesota which included results from pilot scale tests and simulation work demonstrated a significant coarsening of the grind/grade relationship through the use of screens in the grinding circuit instead of hydrocyclones.⁽⁵⁾ This study predicted that a high grade concentrate could be produced at a reasonable but significantly coarser grind than would be required if the mills were closed by hydrocyclones. In fact, this study concluded that the desired product grade could not be obtained with hydrocyclones, even with extremely fine grinding. This coarsening of the grind/grade relationship with improved classification in grinding was also demonstrated on a commercial scale with the addition of screens to all secondary mill lines at the nearby National Steel Pellet Company, now U. S. Steel Keetac, resulting in the production of the same product grade at a significantly coarser grind, specifically, 72% passing 45 microns with screens compared to 79% passing 45 microns in the previous circuit.⁽⁶⁾

3.1 Mina Colquijirca - Sociedad Minera El Brocal S.A.A.⁽⁷⁾

Sociedad Minera El Brocal, located at Tinyahuarco, Pasco Province, Peru, produces lead, zinc, copper and gold. The concentrator flowsheet begins with three rod mills operating in parallel and in open circuit followed by three ball mills operating in parallel and in closed circuit with a bank of ten 10-inch hydrocyclones. As illustrated in Figure 3, rod mill discharge and ball mill discharge are combined in the same sump and pumped to the cyclones. The circulating load is about 350% and overgrinding of the high specific gravity minerals such as galena results in significant slime losses before flotation. Cyclone feed and product particle size distributions are provided in Table 1.

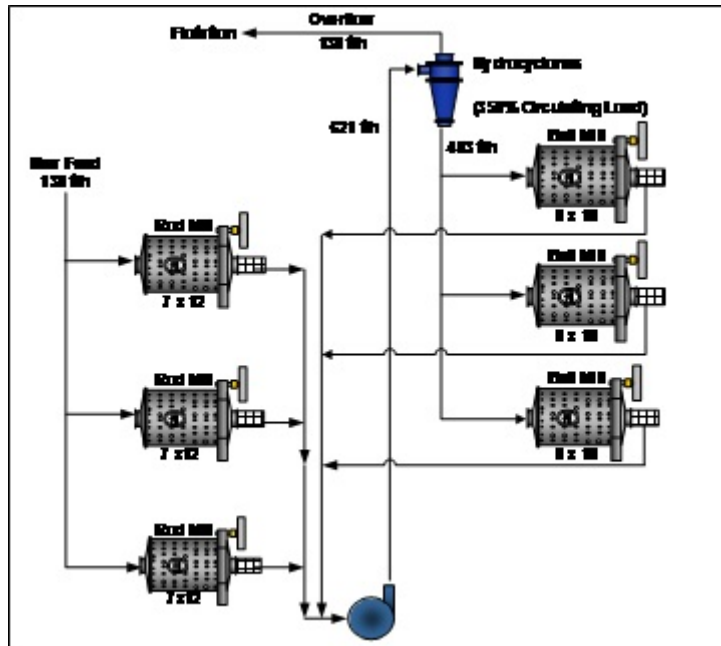

Figure 3. Brocal grinding circuit with hydrocyclone classification.

Brocal desired to increase capacity and was considering the addition of a fourth ball mill. As an alternative, Brocal considered ways to improve grinding efficiency and conducted full-scale Stack Sizer tests. Encouraging test results led to the installation of two 5-deck Stack Sizer screens fitted with 0.50 mm urethane panels in place of the 10 hydrocyclones. The effect was immediate as production increased 11% and lead recovery increased 9% even though Brocal shut down two of the three operating ball mills.

Table 1. Brocal hydrocyclone feed and product particle size distributions

Size (microns)	Cumulative %Passing		
	Cyclone Feed	Cyclone Underflow	Cyclone Overflow
500	72.4	71.6	98.6
300	62.3	59.9	96.2
212	49.2	45.0	91.7
150	36.3	28.4	85.4
75	20.5	11.4	67.7

To take advantage of the increased grinding capacity, Brocal added additional crushing, flotation, and filtration capacity, as well as three additional Stack Sizer screens. One of the two ball mills originally shut down was put back into operation and rod mill rotational speed was increased.⁽⁷⁾ As shown on Figure 4, production has increased from 138 t/h with the cyclone circuit to 245 t/h with the screen circuit, an increase of over 75% with less total grinding energy. The circulating load is about 60% and overgrinding has been minimized; the slime content (particles finer than 10 microns) in the flotation feed has been reduced from 18% to 10%, resulting in significant increases in metal recovery. Screen feed and product particle size distributions are provided in Table 2.

A comparison of the particle size distributions of the grinding circuit product (flotation feed) from the hydrocyclone circuit and the screen circuit is shown in Figure 5. Note the coarsening of the grind/grade relationship as the concentrate grade in both cases was similar.

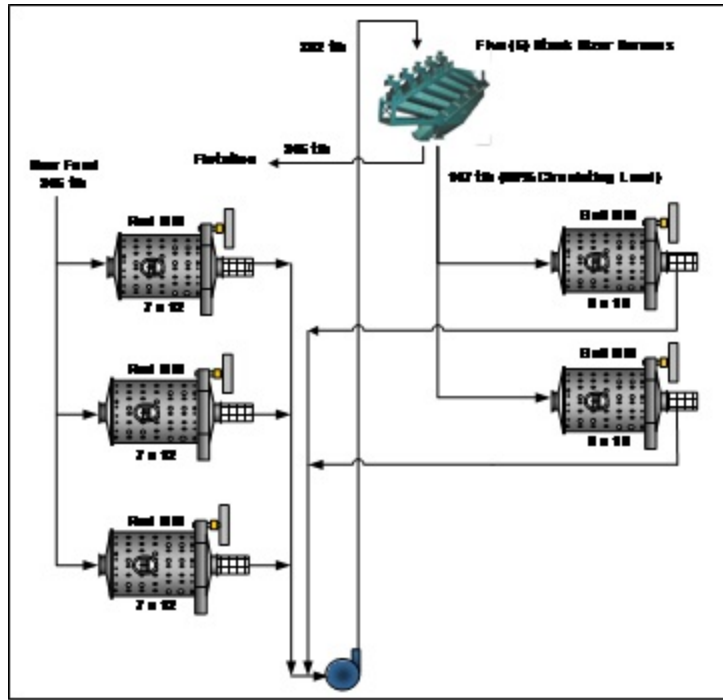

Figure 4. Brocal grinding circuit with screen classification.

Table 2. Brocal screen feed and product particle size distributions

Size (microns)	Cumulative %Passing		
	Screen Feed	Screen Oversize	Screen Undersize
500	69.5	22.2	98.4
300	57.1	11.5	85.2
212	52.8	10.5	78.0
150	42.1	8.7	68.9
75	38.1	8.2	56.3

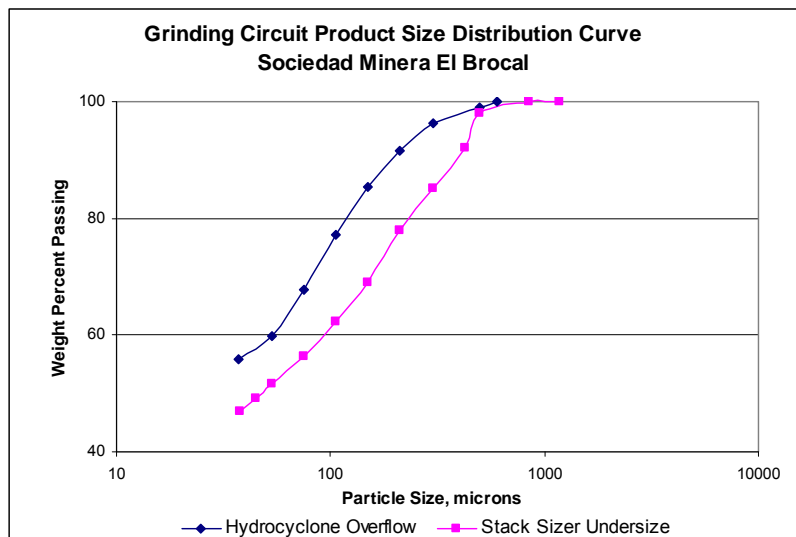

Figure 5. Comparison of circuit products from hydrocyclone and screen circuits at Brocal.

3.2 PhosAgro - OJSC Apatit

OJSC Apatit (Apatit),⁽⁸⁾ a division of PhosAgro, is a phosphate producer located in the Murmansk Region of the Kola Peninsula in Russia. At Apatit, multiple parallel lines of single stage ball mills in closed circuit with either screw classifiers or single and double stage hydrocyclones grind crushed ore. The product from multiple grinding lines is combined and pumped to the flotation plant. Over time, Apatit has experimented with various flowsheet options to improve classification efficiency and increase mill production rates. In 1996 and 1997, tests were conducted with a full scale Multifeed screen and various urethane screen panel openings. Although the test results were encouraging, screens were eliminated as a possible alternative due to the high number of machines required and the limited space available in the vicinity of the grinding mills.

With the development of the high capacity Stack Sizer, Apatit desired to reevaluate screens as a possible method to improve grinding efficiency and increase production rates. They began in 2005 with continuous pilot-scale grinding tests with a ball mill in closed circuit with a hydrocyclone. This was to establish a correlation between the pilot plant and commercial plant operation. Next, a single-deck Stack Sizer screen was installed in place of the hydrocyclone in the pilot plant grinding circuit. The pilot tests demonstrated that the use of screens in place of hydrocyclones would increase production rates and reduce overgrinding and justified the next phase of evaluation, the modification of an existing production line to screen classification.

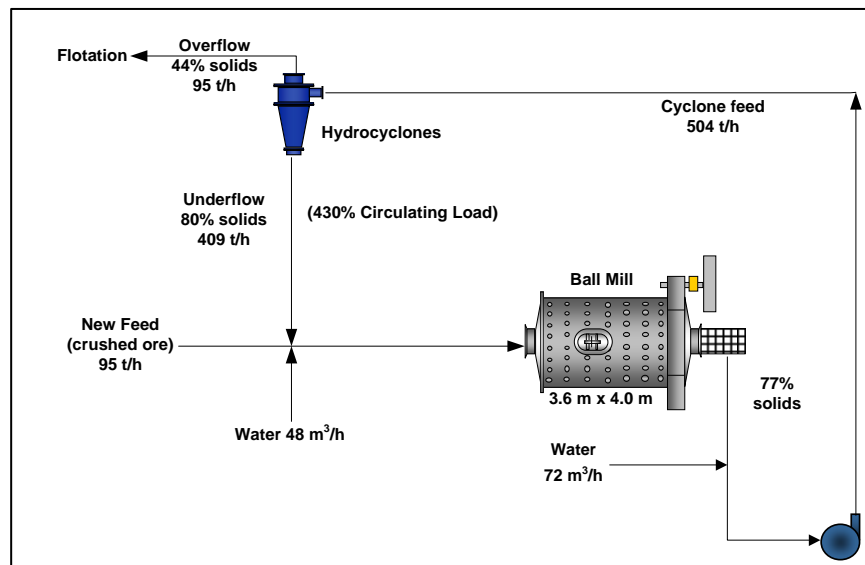

Figure 6. OJSC Apatit Mill 24 grinding circuit with hydrocyclone classification.

Mill 24 was selected for the modification because it was a smaller line and this would minimize the cost of the industrial-scale test. Typical performance of Mill 24 with hydrocyclones is illustrated in Figure 6. The normal production rate was 95 t/h with a circulating load of 430%. Hydrocyclone feed and product particle size distributions are provided in Table 3.

Table 3. OJSC Apatit Mill 24 hydrocyclone feed and product particle size distributions

Size (microns)	Cumulative %Passing		
	Cyclone Feed	Cyclone Underflow	Cyclone Overflow
450	68.8	61.5	100.0
320	57.3	49.0	93.0
200	41.1	31.7	81.3
160	32.3	23.0	72.1
100	21.2	13.3	55.3
71	16.8	9.9	46.4

In 2006, four 5-deck Stack Size screens fitted with 0.39 mm urethane panels were installed with Mill 24 in place of the hydrocyclones. Upon the completion of industrial scale testing, Apatit concluded that grinding mills closed with Stack Sizer screens will see production rate increases of at least 30% compared to mill lines using conventional classification equipment. The modified circuit is shown in Figure 7. The production rate of Mill 24 increased from 95 t/h when closed with hydrocyclones to 124 t/h when the mill circuit was closed with screens. The circulating load decreased from well over 400% to about 135%. Power consumption per ton dropped about 20% to 25% as total mill power was about the same for both circuits. Urethane screen panel life was in the range of 10 to 12 months. Particle size data for the screen feed and products is provided in Table 4.

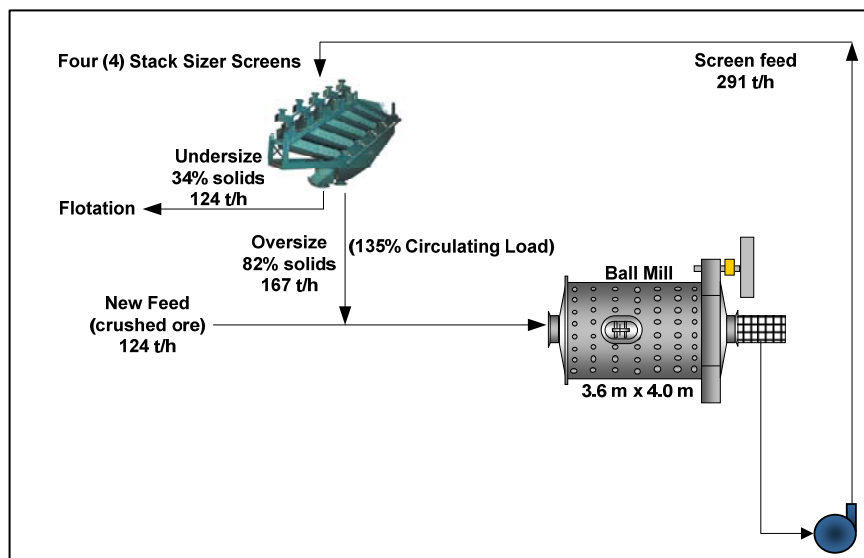

Figure 7. OJSC Apatit Mill 24 grinding circuit with screen classification.

Table 4. OJSC Apatit Mill 24 screen feed and product particle size distributions

Size (microns)	Cumulative %Passing		
	Screen Feed	Screen Oversize	Screen Undersize
450	61.5	32.8	100.0
320	49.3	18.0	91.4
200	38.2	9.9	76.2
160	31.8	6.9	65.2
100	24.4	4.7	50.9
71	19.3	3.6	40.5

The coarsening of the grind/grade relationship is illustrated in Figure 8 with a comparison of the original circuit product (hydrocyclone overflow) and that produced

in the screen circuit (screen undersize). Final product grade from the flotation circuit was similar even though the flotation feed is measurably coarser. Based on the results from the upgrade of Mill 24 to screen classification, and as the space required for the screening equipment is now much less with the Stack Sizer, Apatit has placed orders for 60 Stack Sizers to upgrade 6 large mill lines, each requiring 10 Stack Sizers per line. With the anticipated 30% increase in mill capacity, Apatit is expecting a corresponding decrease in grinding hours to produce the same quantity of flotation feed.

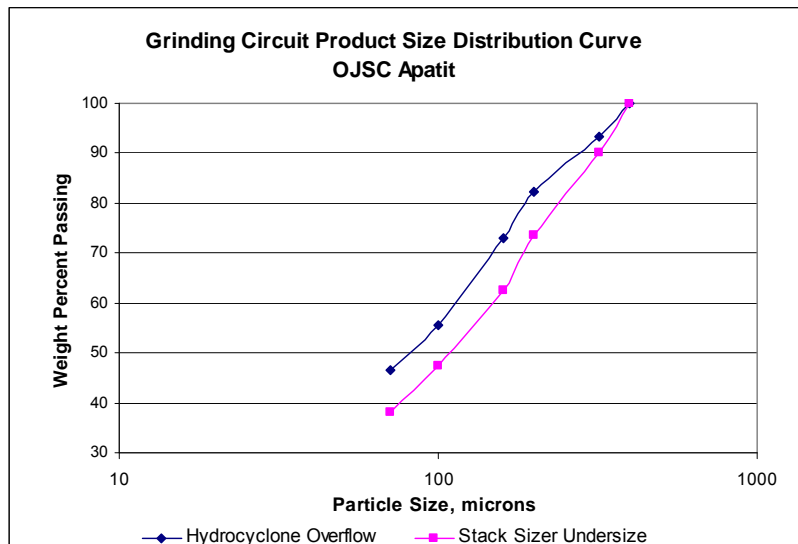

Figure 8. Comparison of circuit products from cyclone and screen circuits at OJSC Apatit.

3.3 OJSC KMAruda

KMAruda⁽⁹⁾ operates an iron ore mine in Russia and run of mine ore contains about 34% total iron. The concentrator flowsheet includes two stages of grinding and three stages of magnetic separation. The primary grinding circuit on each line consists of two ball mills in parallel operating in closed circuit with spiral classifiers. Similarly, the secondary circuit has two ball mills in parallel in closed circuit with hydro-cyclones. All four mills are identical in size. The secondary circuit is illustrated in Figure 9. The first stage magnetic concentrate feeds the cyclones and the cyclone underflow is distributed to the two secondary mills. The mill discharge is fed to the second stage magnetic separators and the magnetic concentrate circulated back to the cyclones. The circuit product goes on to the third stage of magnetic separation.

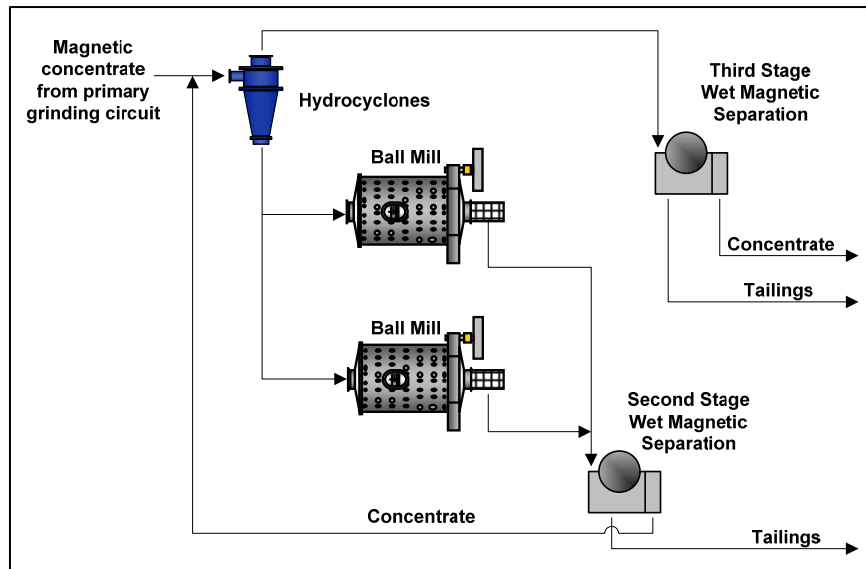

Figure 9. KMAruda second stage grinding circuit with hydrocyclone classification.

Two Stack Sizer screens fitted with 100 micron urethane panels were installed in place of the hydrocyclones on one concentrator production line. Subsequent testing and optimization of the screen circuit resulted in the shut down of one of the two second stage ball mills. The screen circuit is illustrated in Figure 10.

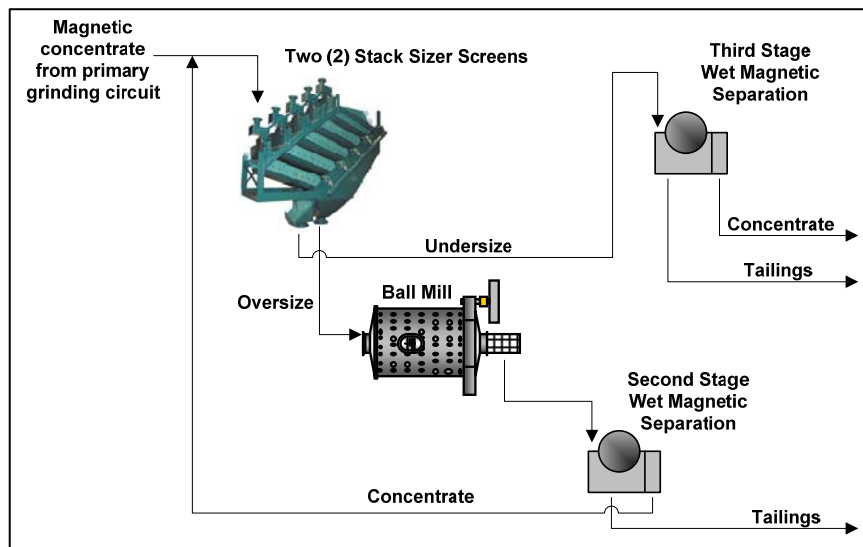

Figure 10. KMAruda second stage grinding circuit with screen classification.

As summarized in Table 5, improved classification efficiency in the second stage circuit resulted in greater line capacity and a significant reduction in power consumption per ton with the elimination of one mill. The circulating load in the screen circuit was lower and considerably coarser at 22.9% minus 71 microns compared to 51% minus 71 microns in the cyclone circuit. While the goal was to maintain the same final product grade, the final concentrate from the screen circuit was also coarser at 82% minus 71 microns compared to 92.5% minus 71 microns on a typical cyclone line. KMAruda also noted that while cyclone underflow was normally around 65% iron, in the screen circuit the screen oversize ranged from 36% to 45% iron, leading to lower iron losses in the second stage of magnetic separation.

Table 5. KMAruda concentrator performance with hydrocyclones and screens in the secondary mill circuit

Parameter	With Hydrocyclones	With Screens
Capacity (t/h)	120	140 to 150
Secondary mill power draw (kW)	1260	630
Secondary mill circulating load (%)	210 to 220	130 to 160
Secondary mill circulating load size (% minus 71 μm)	51.0	22.9
Final concentrate size (% minus 71 μm)	92.5	82.0
Final concentrate grade (%Fe)	65.85	66.00
Final concentrate iron recovery (%)	82.2	84.6
Final tails grade (%Fe)	10.9	9.09

3.4 Minera Cerro Lindo

Minera Cerro Lindo⁽¹⁰⁾ is located southwest of Lima, Peru and produces copper, lead, and zinc concentrates. The grinding circuit at Cerro Lindo consists of a 14.5 ft x 23.5 ft ball mill operating in closed circuit with a bank of 26-inch hydrocyclones (Figure 11). The circulating load is about 260%. Cyclone feed and product particle size distributions are provided in Table 6.

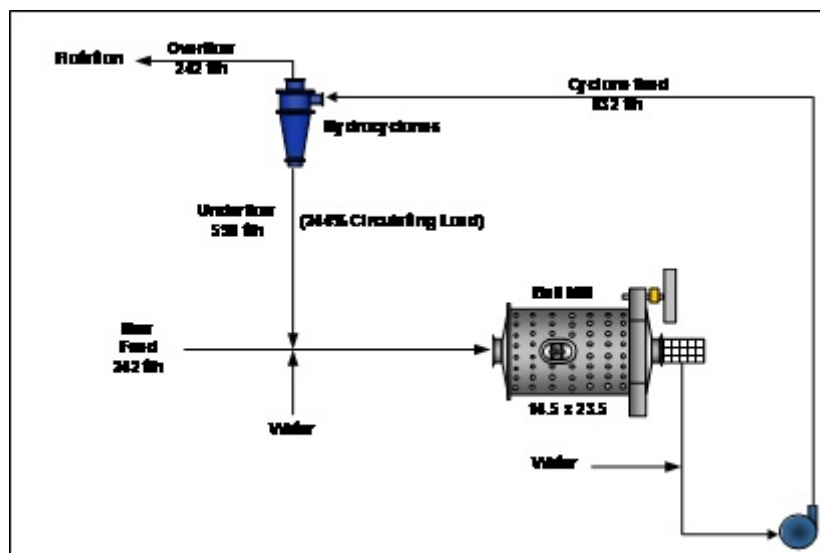

Figure 11. Cerro Lindo grinding circuit with hydrocyclone classification.

Table 6. Cerro Lindo hydrocyclone feed and product particle size distributions

Size (microns)	Cumulative %Passing		
	Cyclone Feed	Cyclone Underflow	Cyclone Overflow
500	100.0	100.0	100.0
300	100.0	100.0	100.0
212	63.9	52.1	94.4
150	46.1	31.0	85.4
75	22.5	8.4	58.9

Following the success of screen classification in grinding circuits at Brocal and other polymetallic mining operations in Peru, Cerro Lindo initiated a program to improve concentrator performance. Following full-scale testing, four Stack Sizer screens were installed in place of the 26-inch diameter hydrocyclones. Three screens are fitted with 0.23 mm urethane panels and one with 0.18 mm urethane panels. As shown in

Figure 12, the circulating load has decreased to 108% and line capacity has increased 13.6% to 275 t/h. Screen feed and product particle size distributions are provided in Table 7.

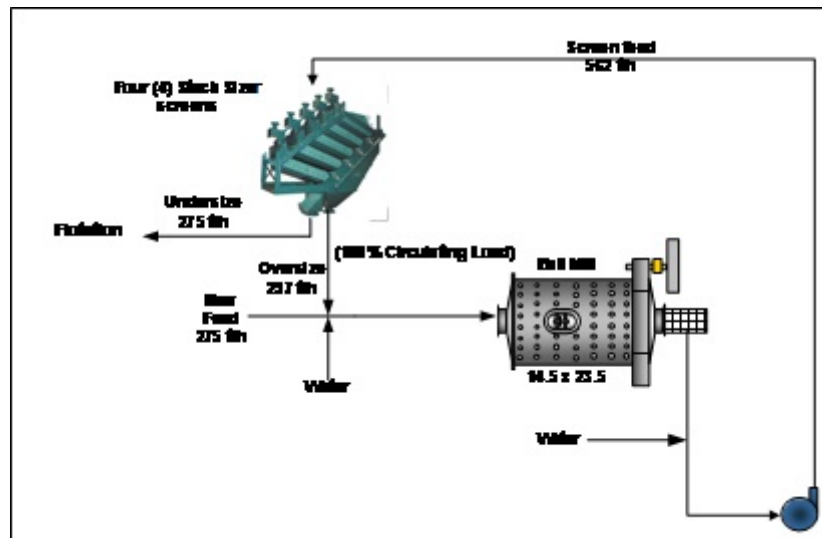

Figure 12. Cerro Lindo grinding circuit with screen classification.

Table 7. Cerro Lindo screen feed and product particle size distributions

Size (microns)	Cumulative %Passing		
	Screen Feed	Screen Oversize	Screen Undersize
500	91.0	88.0	100
300	75.3	54.9	99.3
212	59.4	31.1	90.6
150	47.8	20.5	75.0
75	30.4	9.9	47.0

Table 8 highlights some of the benefits of the change to screen classification. In the screen circuit, while the mill discharge product has more minus 75 micron material, flotation feed has less minus 75 micron. The P_{80} is coarser in the screen circuit at 160 microns compared to 141 microns with the cyclone circuit. Steel consumption per kwh has decreased. Tailings filtration capacity also increased as the tailings are now coarser and more homogenous.

Table 8. Comparison of Cerro Lindo concentrator performance with hydrocyclones and screens

Parameter	With Hydrocyclones	With Screens
Capacity (t/h)	242	275
Circulating load (%)	244	108
Steel consumption (g/kwh)	778	696
Mill discharge particle size (% minus 75 μ m)	24	30
Mill solids (%)	83	79
Flotation feed particle size (% minus 75 μ m)	55	47
Flotation feed P_{80} (μ m)	141	160

REFERENCES

- 1 VALINE, S. B. AND J. E. WENNEN. 2002. Fine Screening in Mineral Processing Operations. **Mineral Processing Plant Design, Practice, and Control**. A. L. Mular, D. N. Halbe, and D. J. Barratt, editors. SME.

- 2 DAVIS, E. W. 1925. Ball Mill Crushed in Closed Circuits with Screens. **Bulletin of University of Minnesota, Mines Experiment Station Bulletin No. 10**. 28:42.
- 3 ALBERT, E. 1945. Characteristics of Screen-Circuit Products. **Min. Tech.** T.P. 1820.
- 4 HUKKE, R. T. AND H. ELAND. 1965. The Relationship Between Sharpness of Classification and Circulating Load in Closed Grinding Circuits. **Transactions**. Society of Mining Engineers.
- 5 MURR, D. L., J. E. WENNEN, AND W. J. NORDSTROM. 2009. Essar Steel Minnesota, Concentrator Flowsheet Development. **70th Annual University of Minnesota Mining Symposium**. Duluth, Minnesota.
- 6 WENNEN, J.E., W.J. NORDSTROM, AND D.L. MURR. 1997. National Steel Pellet Company's Secondary Grinding Circuit Modifications. **Comminution Practices**. 19-25.
- 7 AQUINO, B. AND J. VIZCARRA. 2007. Re-engineering the Metallurgical Processes at Colquirjirca Mine, Sociedad Mineral El Brocal S.A.A. **Mineria**, 30-38.
- 8 OJSC Apatit. 2009. Written communication.
- 9 PELEVIN, A. E. AND M. V. LAZEBNAYA. 2009. Application of Derrick Screens in Locked Grinding Circuit at the KMaruda Mining Complex Concentrating Plant. **Mineral Processing Journal (Russia)**. No. 2.
- 10 TICSE, F. 2009. Milpo-Cerro Lindo. Information provided during plant visit.